

# IRIS

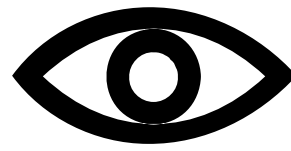

## FLAME MONITORING SYSTEM

### MODEL P520 SIGNAL PROCESSOR APPLICATION MANUAL



# TABLE OF CONTENTS

<p>Model P520 ----- 4</p> <p>WIRING AND INSTALLATION ----- 4</p> <p>FIGURE 1 - TERMINAL WIRING OF REAR PCB4</p> <p>CARD FRAMES ----- 4</p> <p>WIRING THE REAR PC BOARD ----- 5</p> <p>FIGURE 2 - WIRING VIEWING HEAD ----- 6</p> <p>FIGURE 3 - WIRING AND ASSEMBLY</p> <p style="padding-left: 20px;">VIEWING HEAD ----- 7</p> <p>OPTIONAL LTA ADAPTER ----- 7</p> <p>WIRING OF VIEWING HEAD ----- 8</p> <p>POWER SUPPLY ----- 9</p> <p>FIGURE 4 - POWER SUPPLY TABLE ----- 9</p> <p>FIGURE 5 - 19" HALF-CARD FRAME WITH</p> <p style="padding-left: 20px;">STANDOFFS ----- 9</p> <p>FACTORY STOCKED POWER SUPPLIES ----- 10</p> <p>REDUNDANT POWER SUPPLIES ----- 10</p> <p>SELF-CHECKING FUNCTION ----- 10</p> <p>REMOTE I/O MODULE ----- 11</p> <p>FIGURE 6 - REMOTE I/O MODULE ----- 11</p> <p>FIGURE 7 - IRIS P520 I/O MODULE</p> <p>SCHMATIC ----- 12</p> <p>FIGURE 8 - FIELD WIRING TO I/O MODULE ----- 13</p> <p>FIGURE 9 - I/O MODULE SHOWING</p> <p style="padding-left: 20px;">SELF-CHECKING &amp; FLAME RELAY</p> <p style="padding-left: 20px;">CONTACTS ----- 14</p> <p>APPROVALS ----- 15</p> <p>POWERING UP THE P520 ----- 15</p> <p>SET POINTS ----- 16</p> <p>FIGURE 10 - SET POINTS ----- 16</p> <p>CHANGING SET POINTS ----- 16</p> <p>FLAME FAILURE RESPONSE</p> <p style="padding-left: 20px;">TIME (F.F.R.T.) ----- 16</p> <p>4-20mA REMOTE OUTPUT ----- 17</p> <p>FIGURE 11 -REMOTE METER ANALOG OUT-</p> <p style="padding-left: 20px;">PUT ----- 17</p> <p>INSTALLATION OF VIEWING HEAD ----- 17</p> <p>FIGURE 12 - VIEWING HEAD</p> <p style="padding-left: 20px;">CROSS-REFERENCE TABLE ----- 18</p> <p>SIGHTING OF THE VIEWING HEAD ----- 18</p> <p>MULTIBURNER REQUIREMENTS ----- 19</p> <p>FIGURE 13 - CUTOFF FREQUENCIES ----- 19</p> <p>MULTIPLE VIEWING HEADS ----- 19</p> <p>DETERMINING SIGHT PIPE SIZE ----- 20</p> <p>SELECTING THE PIPE ----- 20</p> <p>MOUNTING HOLE ----- 20</p> <p>MOUNTING OF SIGHT PIPE ----- 20</p> <p>INSTALLING THE VIEWING HEAD ----- 20</p> <p>PURGE AIR ----- 20</p> <p>SET UP AND ADJUSTMENT PROCEDURES - 20</p>	<p>SIGHTING ADJUSTMENT ----- 21</p> <p>INITIAL SET UP ----- 21</p> <p>ADJUSTING SET POINTS ----- 22</p> <p>TROUBLESHOOTING GUIDE ----- 23</p> <p>NOISE INTERFERENCE AND GROUNDING ----- 23</p> <p>S506 VIEWING HEAD ----- 24</p> <p>S506 SELF-CHECKING VIEWING HEAD ----- 25</p> <p>S509 VIEWING HEAD ----- 25</p> <p>S511 VIEWING HEAD ----- 26</p> <p>S512 VIEWING HEAD ----- 26</p> <p>ORIFICING ----- 28</p> <p>FIGURE 14 - ORIFICING: SIGNAL-REDUCING</p> <p style="padding-left: 20px;">CHARACTERISTICS OF DISCS ----- 28</p> <p>SIGNAL SOURCES ----- 28</p> <p>ANGLE OF VIEW OF VIEWING HEAD ----- 29</p> <p>FIGURE 15 - VIEWING HEAD: ANGLE OF VIEW</p> <p style="padding-left: 20px;">- DISTANCE AND DIAMETER ----- 30</p> <p>APPLICATION OF IRIS VIEWING HEADS ----- 30</p> <p>LOW NO<sub>x</sub> APPLICATIONS ----- 31</p> <p>APPLICATION OF P520 ----- 31</p> <p>USING A PLC WITH IRIS FLAME MONITOR ----- 31</p> <p>FIGURE 16 - VIEWING HEAD APPLICATION</p> <p style="padding-left: 20px;">TABLES ----- 32</p> <p>FIGURE 16 - VIEWING HEAD APPLICATION</p> <p style="padding-left: 20px;">TABLES Cont'd. ----- 33</p> <p>BASIC BURNER START CIRCUIT ----- 34</p> <p>FIGURE 17 - BASIC BURNER START CIRCUIT ----- 35</p> <p>MODULE COMMUNICATIONS ----- 36</p> <p>MODBUS COMMUNICATION ----- 36</p> <p>COMMUNICATING WITH</p> <p style="padding-left: 20px;">MODICON PLC ----- 37</p> <p>COMMUNICATION WITH HUMAN-</p> <p style="padding-left: 20px;">INTERFACE HOST COMPUTER ----- 37</p> <p>RS-232 to RS-422 CONVERSION ----- 37</p> <p>SETTING ADDRESSES ----- 37</p> <p>TECHNICAL HELP ----- 38</p> <p>FIGURE 18 - SPECIFICATIONS ----- 39</p> <p>FIGURE 19 - MODEL P520 SIDE VIEW ----- 40</p> <p>FIGURE 20 - S5XX VIEWING</p> <p style="padding-left: 20px;">HEAD DIMENSIONS ----- 40</p> <p>FIGURE 21 - 4 MODEL P520s FRONT AND</p> <p style="padding-left: 20px;">REAR VIEW MOUNTED IN FACF ----- 41</p> <p>FIGURE 22 - IR VIEWING HEAD LOCATION ----- 42</p> <p>FIGURE 23 - UV VIEWING HEAD</p> <p style="padding-left: 20px;">LOCATION ----- 42</p> <p>FIGURE 24 - OPPOSED FIRED VIEWING HEAD</p> <p style="padding-left: 20px;">SIGHTING ----- 43</p> <p>FIGURE 25 - VIEWING HEAD MOUNTING. ----- 43</p> <p>INDEX ----- 44</p>
---	--

# FIGURE INDEX

FIGURE 1 - TERMINAL WIRING OF REAR PCB ----- 4

FIGURE 2 - WIRING VIEWING HEAD ----- 6

FIGURE 3 - WIRING AND ASSEMBLY VIEWING HEAD ----- 7

FIGURE 4 - POWER SUPPLY TABLE ----- 9

FIGURE 5 - 19" HALF-CARD FRAME WITH STANDOFFS ----- 9

FIGURE 6 - REMOTE I/O MODULE ----- 11

FIGURE 7 - IRIS P520 I/O MODULE SCHEMATIC ----- 12

FIGURE 8 - FIELD WIRING TO I/O MODULE ----- 13

FIGURE 9 - I/O MODULE SHOWING SELF-CHECKING & FLAME RELAY CONTACTS ----- 14

FIGURE 10 - SET POINTS ----- 16

FIGURE 11 - REMOTE METER ANALOG OUTPUT ----- 17

FIGURE 12 - VIEWING HEAD CROSS-REFERENCE TABLE ----- 18

FIGURE 13 - CUTOFF FREQUENCIES ----- 19

FIGURE 14 - ORIFICING: SIGNAL-REDUCING CHARACTERISTICS OF DISCS ----- 28

FIGURE 15 - VIEWING HEAD: ANGLE OF VIEW - DISTANCE AND DIAMETER ----- 30

FIGURE 16 - VIEWING HEAD APPLICATION TABLES ----- 32, 33

FIGURE 17 - BASIC BURNER START CIRCUIT ----- 35

FIGURE 18 - SPECIFICATIONS ----- 39

FIGURE 19 - MODEL P520 SIDE VIEW ----- 40

FIGURE 20 - S5XX VIEWING HEAD DIMENSIONS ----- 40

FIGURE 21 - 4 MODEL P520s FRONT AND REAR VIEW MOUNTED IN FACF ----- 41

FIGURE 22 - IR VIEWING HEAD LOCATION ----- 42

FIGURE 23 - UV VIEWING HEAD LOCATION ----- 42

FIGURE 24 - OPPOSED FIRED VIEWING HEAD SIGHTING ----- 43

FIGURE 25 - VIEWING HEAD MOUNTING ----- 43

**Model P520**

The P520 is a Signal Processor used with the IRIS Model 5xx- or 55x-series Viewing Heads. The P520 is a *plug-in* module, designed to conform to the DIN 41494 19-inch card frame system. It is designated as 3U high and 21HP wide, or 5.06 x 4.18 inches, and its length is 220mm (8.66 inches). A rear backplane PCB is required for termination.

**WIRING AND INSTALLATION**

Before wiring or installing the P520, we recommend that you read the companion colour brochure describing the hardware and the basic operation of this signal processor.

**CARD FRAMES**

The backplane card frame consists of a kit of parts that will make up a 19-inch card frame. This kit does not include the card guides that the module slides into. Four card guides are required for each P520 module; therefore, a total of sixteen card guides would be required to mount four P520 modules. The card guides are packaged in quantities of 10 per pack.

This rack also requires spacers for the top and bottom of the rear backplane PCB, and the spacers are available in packs of two.

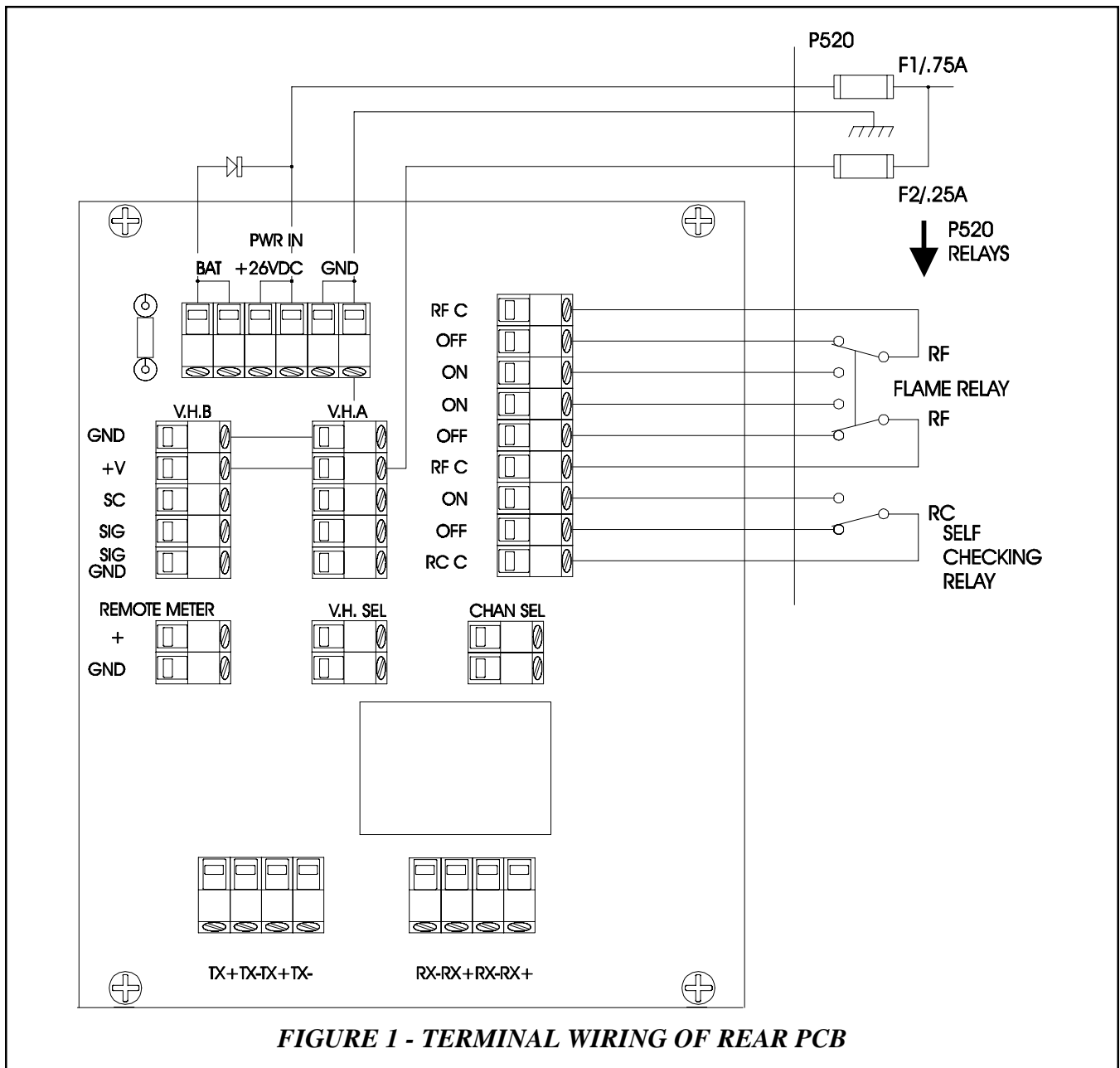

**FIGURE 1 - TERMINAL WIRING OF REAR PCB**

The card frame kit does not include the card guides, so these must be ordered separately - as with the backplane type card frame. All card frames and accessories are available from the factory.

A half-card frame, or “half rack” (9.5 inches wide) is available as an alternative to the 19-inch card frame, and this half rack will mount two P520 modules. Again, the kit does not contain the card guides, which must be ordered separately. As an option, the card frame can be assembled with the necessary parts ready for mounting (IRIS part numbers FACF, and FACF-1/2).

## WIRING THE REAR PC BOARD

A view of the rear backplane PCB is shown in Figure 1. The relay outputs are located on the nine-contact terminal block (upper right).

RF C refers to the common terminal of the *flame relay*, with ON being flame on, and OFF being flame off. You will note that there are two sets of contacts used for the flame relay.

SC C refers to the common terminal of the *self-checking relay*. There is only one pair of contacts used for the self-checking function. Here, the designation ON refers to the self-checking taking place in a normal manner. OFF indicates a failure in the viewing head or processor resulting from

- the hardware (i.e. the shutter mechanism in the viewing head, or the output relay itself);
- electronic components anywhere, or internal software in the P520; or
- the power to the unit is OFF – the most likely condition

The horizontal set of six terminals (top left) is used for the main power into this plug-in module (PWR IN). Each designated terminal is a double terminal, or pair, so that the wiring from the power supply can be “daisy chained” from one P520 to the next without having to twist wires together into one termination.

The pair designated BAT is for *battery backup*, if used. Note the rectifier (to the left of this group of terminals) used internally to prevent the 26 VDC

main power supply from feeding into the battery. The backup battery, if used, should be 24 volts, to ensure that the 26 VDC power feeding the P520 will not feed back into the battery. In other words, no current will flow from the battery as long as voltage of the main power supply is above that of the battery. The negative side of the battery goes to the GND terminal on the right.

Figure 1 shows how these terminals are connected inside the P520. Note the two fuses marked F1 and F2. F1 is the main power fuse for the signal processor as well as the viewing head(s), and is rated at .75 Amp. Fuse F2 feeds only to the viewing head(s), and is rated at .25 Amp. Each viewing head draws about 100mA, so this output can supply only two viewing heads; so, if more than two viewing heads are required, it will be necessary to increase the value of fuse F2. Consult the factory for details. On newer units (those with NO, CAL, and YES in red letters on the front panel) these fuses are self-resetting types, and will recover from an overload automatically after power is removed from the P520 for 10 seconds.

Just below the six-pin PWR IN terminals are two, five-pin vertically-mounted *viewing head* terminals identified as V.H. A. and V.H. B. If only one viewing head is used, you must wire to the V.H. A. terminals. Below the V.H. A. terminals are two terminals marked V.H. SEL (*viewing head selector relay*). Energizing this connection with 26 VDC will cause the relay on this PCB to switch to viewing head B.

Only the *viewing head signal wire* (SIG) and the *signal ground wire* (SIG GND) are switched with this changeover relay; the 26 VDC and power ground circuit is not disturbed. Make sure that the viewing head signal wire and signal ground (braided shield in the four-conductor cable) are both connected, because this ground connection is the only return path for the signal and self-checking circuit. The 26 VDC used to switch this relay can be connected without regard to polarity. The two terminals marked V.H. SEL go directly to the relay coil.

The two-pin terminal to the right of V.H. SEL designated CHAN SEL is used for selecting channel A or channel B on the P520. Energizing this pair of terminals causes the B channel to be selected.

## IRIS MODEL P520 APPLICATION MANUAL

Polarity must be observed when wiring this connection (the positive terminal is on the top). This is an isolated input, so two wires are required. Any DC voltage from 7.5 to 30 may be used. The current required will depend upon the voltage, because this is a photocoupler interface circuit with a 3900 ohm resistor feeding the LED light source.

For example: a 26 VDC voltage will result in a current flow of  $25/3900 = .0064$  Amp.

If flame is being detected and the channels are switched, the flame relay will remain energized for one cycle regardless of the new set points, allowing channel changes “on the fly,” so to speak. If the new flame OFF set point is equal to or greater than the current signal count, then the flame relay will de-energize on the subsequent cycle.

The remaining two-pin terminal designated REMOTE METER (to the left of the V.H. SEL terminals) is for the *remote meter connection*. This output is a current-driven signal that ranges from 0 to 20 mA for remote meters, and can be switched to a range of 4 to 20 mA for DCS (*distributed control system*) applications (refer to section **4-20mA REMOTE OUTPUT**). Connect the terminal marked “positive” to the positive meter terminal. This current signal can be used with a volt meter by feeding the signal to a resistor connected to the ground. The voltage developed across the resistor will follow Ohm’s law  $V = IR$ .

For example: a 3-volt meter can be used with a resistor of  $3/.02 = 150$  ohms, which will result in a full-scale reading of 3 volts for a 20mA output.

The terminals called TX+, TX-, RX+, and RX- (at the bottom of the PCB) are used for the serial communication link. They are also in pairs to accommodate “daisy chaining,” but the pairs are arranged for twisted pairs instead of adjacent redundancy. The serial communication is achieved by using ASCII character code transmission at 4800 through the RS-232 com ports on the host computer. The P520 uses RS-422 data transmission which is over two, twisted pairs that are differentially transmitted and received, allowing long wire runs to be used through noisy environments. An RS-232 to RS-422 converter must be used to communicate with the P520, and the connections are made to the terminals marked TX+, TX-, RX+ and RX-. The transmitting, twisted pair goes to the TX terminals, and the receiving, twisted pair goes to the RX terminals.

Note: the terms “transmit” and “receive” used here with respect to the P520 will be *reversed* with respect to the RS-232 connection on the host computer. Refer to later sections in this manual for a detailed description of the software and how it is to be used with the P520.

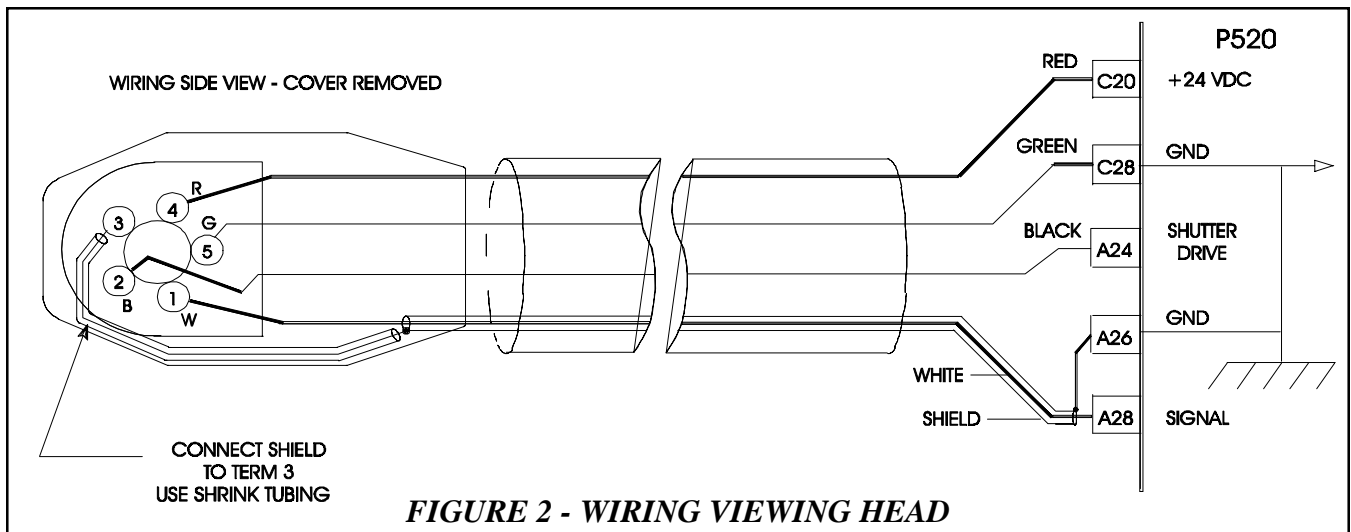

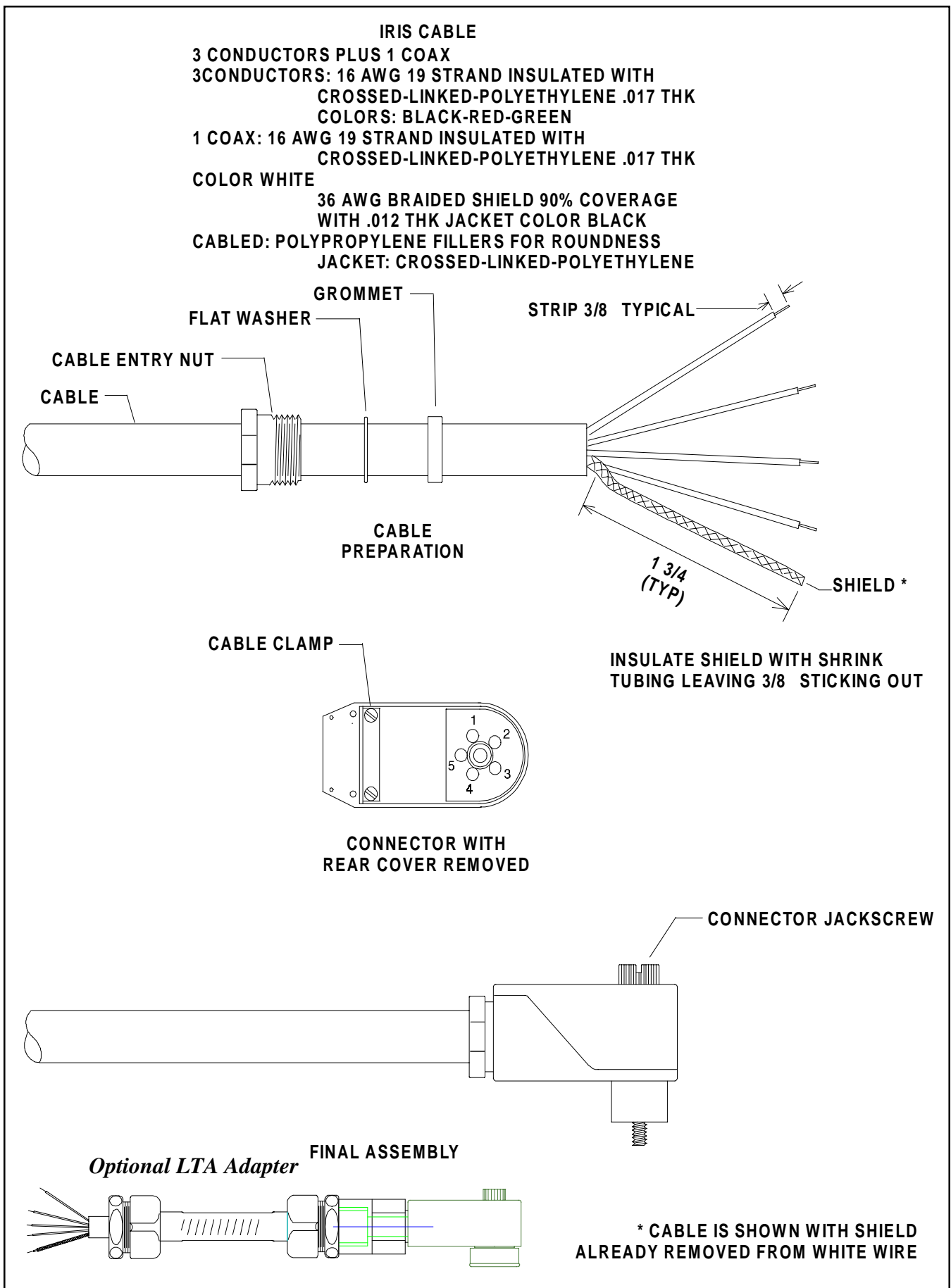

FIGURE 3 - WIRING AND ASSEMBLY VIEWING HEAD

## WIRING OF VIEWING HEAD

Wiring of the viewing head is made to the terminals on the rear backplane PCB. These terminals are described as follows:

TERM	DESCRIPTION
+V	24 VDC power to viewing head
GND	Power Ground
SC	Self check/shutter drive signal to viewing head
SIG	Flame signal from viewing head
SIG GND	Signal ground

Figure 2 shows a four-conductor cable to the viewing head. Note that the flame signal wire going to terminal 7 on the M502 is shielded, and the shield is terminated at **both** ends of the cable.

A *source impedance resistor* is required when using the P522 module with a S550 viewing head. This resistor should be 330W for viewing head cable runs up to 500 feet, and it should be 150W for cable runs 500 feet to 1000 feet. The resistor should be installed across the SC and SIG GND terminals on the rear backplane PCB. A 1/4 watt resistor is suitable.

Originally, specifications of the IRIS Model 500 instructed that a five-conductor cable be used, with one wire shielded. However, the standard is now a **four-conductor cable**, with one wire shielded. In this case, the shield is used as the signal ground wire that goes to terminal SIG GND on the P520 (terminal 8 on the M502) and to pin 3 on the viewing head plug. The shield should be a braided type for this application –do not use a foil type shield– so that a solid signal ground is maintained. This signal ground shield is also the self-checking circuit return path. Refer to Figures 2 and 3 for wiring details.

Connections of the IRIS cable to the viewing head plug should be performed as follows:

After removing the plug from its packaging, take the cable entry nut out of its housing. Remove rubber grommet and flat sealing washer. With a pair of long-nosed pliers, remove the center ring only of the rubber grommet.

1. Strip two inches of the cable's outer cover from the cable, removing any cellophane wrap or filler material, and strip the insulation from the shielded wire (if insulated over shield) a full two inches, to expose shield.
2. Slide the shield back until a bulge develops close to where the wire exits the cable's outer covering.
3. Carefully spread a few strands of the shield at the bulge –making sure not to break any strands– to create an opening, and slip wire out of shield through opening.
4. Carefully return shield to original shape and length by pulling gently, then cover with plastic shrink tubing to prevent shorts.
5. Slide nut (with threads toward the cable end), the washer and the grommet onto the cable approximately six inches.
6. Slip the cable through the bottom opening of the connector, making sure that the cable's outer jacket is secure under the cable clamp, and tighten the two screws on the cable clamp.
7. Reassemble the grommet, flat washer and cable entry nut, and tighten.
8. Before wiring to connector, strip each wire 3/8 inch, as shown in assembly diagram.
9. Proceed to wire the connector. Refer to Figure 2 for terminal locations.
  - Connect the viewing head signal wire WHT (the shielded wire) to terminal No. 1 by inserting it into the opening, then tightening the retaining screw.
  - Connect the shutter drive signal wire BLK to terminal No. 2.
  - Connect the signal ground shield from the WHT wire to terminal No. 3 with shrink tubing.

- Connect the 24 VDC power wire RED to terminal No. 4.
- Connect the power ground wire GRN to terminal No. 5.
- Assemble the back of the plug and insert jackscrew through the plug assembly.

The cable wiring at the other end going to the signal processor is easier. The cable should be prepared in a similar way to the plug end – particularly the shield from the WHT wire. Make sure the shield doesn't touch the other terminals.

**POWER SUPPLY**

Careful consideration should be given to the power supply used for the P520. 26 VDC is used to back bias the “steering” rectifier, as shown in Figure 1, to prevent the power from feeding into the 24 VDC supply. Each P520 module draws approximately 200mA, and each viewing head draws about 100 mA of power (26 VDC). Also, the amount of current drawn by the P520 will depend upon other factors that can affect the peak current, such as whether or not there is flame being detected, the remote meter output is connected, and serial communication is occurring.

The viewing head is powered through the P520 via a .25A self-resetting fuse. In other words, the 26 VDC

power feeds into the P520 (through a .75A self-resetting fuse) and feeds back out through a 250 mA fuse to the viewing head, resulting in a current drain of about 300 mA for each P520 (with one viewing head). This small amount of current means that one power supply could support a number of P520 modules (the disadvantage, of course, is that if the power supply fails, all the P520 modules connected go off). The self-resetting fuses change to high resistance when their current ratings are exceeded, but recover to their normal low resistance when power is removed.

IRIS MODEL P522 POWER SUPPLY CAPCITY IN WATTS					
QTY	7.5W	15W	30W	50W	100W
1		X	X	X	X
2			X	X	X
3			X	X	X
4				X	X
5					X
6					X
7					X
8					X
9					X
10					X

**FIGURE 4 - POWER SUPPLY TABLE**

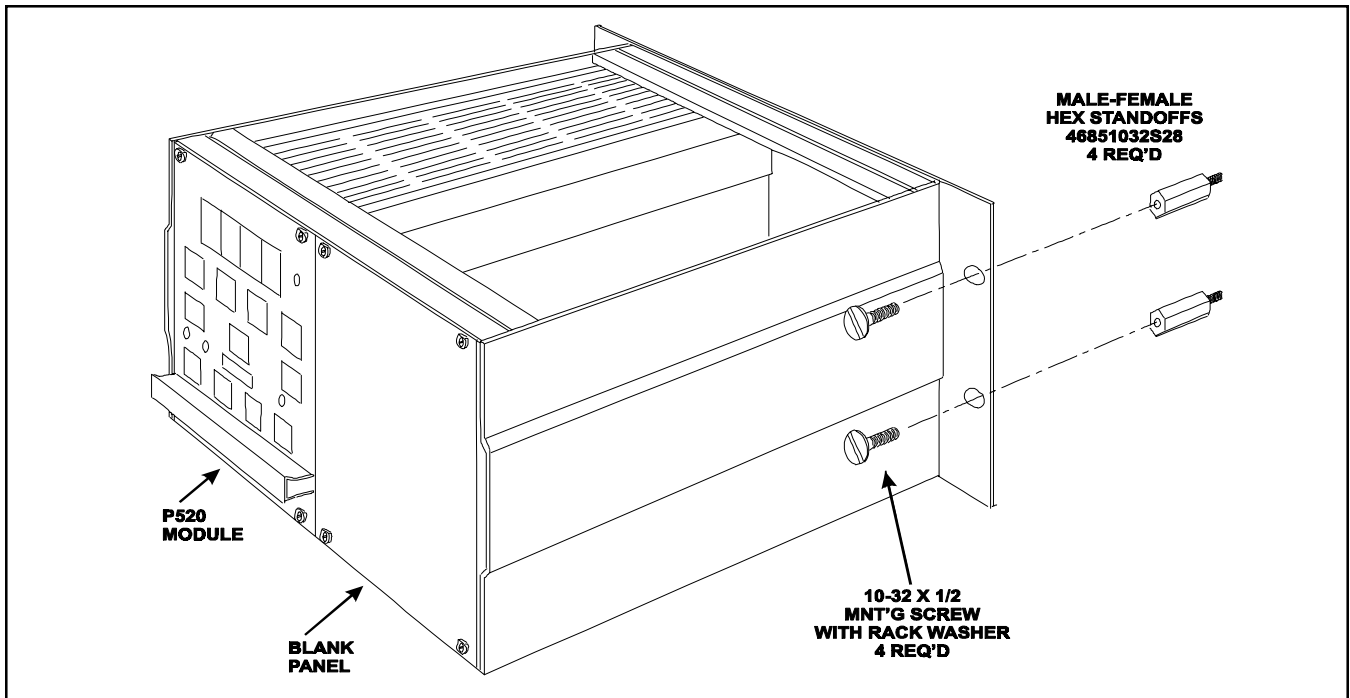

**FIGURE 5 - 19" HALF-CARD FRAME WITH STANDOFFS**

### FACTORY STOCKED POWER SUPPLIES

Power supplies are readily available from the factory for the P520 modules. The IRISPS030 power supply will support up to three P520 modules with one viewing head each. The 50-watt power supply will power up to six or seven P520 modules with one viewing head each (30 watt). The IRISPS050 power supply will support up to six P520 modules with one viewing head each (50 watt). And the IRISPS100 will power up to twelve P520 modules with one viewing head each (100 watt). These “switching type” power supplies are efficient and very compact. To obtain the size and weight of the power supplies, contact IRIS Systems Inc.

Each power supply can be either rail mounted or panel mounted, and it is up to each end user to determine their installation preferences and requirements.

We recommend that not more than four P520 signal processors be supported by one 26 VDC power supply. For instance, four P520 processors with one viewing head each equals a total of 31.2 watts – a relatively small power supply, particularly if an efficient, switching type is used.

Other possible combinations can be used; for instance, the battery backup terminal could be used for redundancy. However, care must be taken with these redundant schemes to make sure that failure of the primary power supply won't affect the backup power supply, as well.

### REDUNDANT POWER SUPPLIES

It may be more economical to use larger-capacity power supplies for applications using 12 or more P520 signal processors.

For example: the 100-watt power supply available from the factory can handle twelve P520 modules, each with one viewing head. Should the power supply fail, a redundant scheme utilizing two power supplies with “steering” rectifiers to prevent current from flowing into a failed power supply output would prevent the 12 flame monitors from being de-energized.

The positive output from each power supply is wired to the anodes of the MBR 1545CT. This dual, Schottky-type rectifier, rated for 15 Amps, will present a low forward voltage drop for this application. Both power supplies can be adjusted for 26V output, and a low-voltage indicator light can be used on the output of each power supply to monitor their outputs.

Larger power supplies can be used with this redundant wiring scheme if there are more than twelve P520 modules in a system. Care should be taken when wiring multiple P520s to ensure the selected bus wires will carry the current. The rear PCB on the P520 will accommodate a wire size up to 14AWG, allowing for relatively high currents.

### SELF-CHECKING FUNCTION

When energized, the self checking function indicates that both the P520 and the viewing head are functioning properly. The software in the P520 activates the self-checking relay only if there are less than 10 pulses coming in from the viewing head during each dark period. To energize this relay, the software must generate pulses –at a particular rate and with a specific duty cycle– to a self-checking circuit. If this regular pattern is not maintained, or if any of the circuitry fails, the relay will drop out. The blinking LED on the front panel labelled SELF-CHECK O.K. is evidence that voltage is applied to the coil of this self-checking relay, because both are energized by the same voltage. The difference is that the voltage to the coil is applied steadily, while the voltage from the relay to the LED is gated on and off by the software in conjunction with the pulses counted during the dark period.

Note that, with regard to the viewing head, the self checking function still works the same way as with the M502, A513 and D504 signal processors. For instance, a runaway UV tube will cause a “lockout condition” (more than 10 pulses counted during the dark period). (Refer to section **EXPLANATION OF 1-9,  $\geq 10$  PULSES COUNTED DURING THE DARK PERIOD**, in the Model 500 Signal Processor Application Manual.)

A runaway UV tube or any component failure, including the shutter, will cause a lockout condition that will de-energize the flame relay. The LOCKOUT light on the P520 will indicate this condition, requiring a reset to return to normal flame monitoring mode. A reset can be achieved only if the lockout condition has been corrected, and can be performed from the front panel (by pressing the RESET button), or remotely through the serial communication.

**REMOTE I/O MODULE**

An *input/output* (I/O) module is available for implementing the basic functions described in the previ-

ous section. It will also help facilitate the field wiring in applications where it is impractical to wire to the rear PCB of the P520.

For example: in a standard NEMA 12 wall-mounted or free standing enclosure, a card frame cannot be mounted unless rack-mounting rails or rack-mounting angles are installed. In this instance, where there is only one relay panel, the standard card frame can be reversed and mounted directly to the panel.

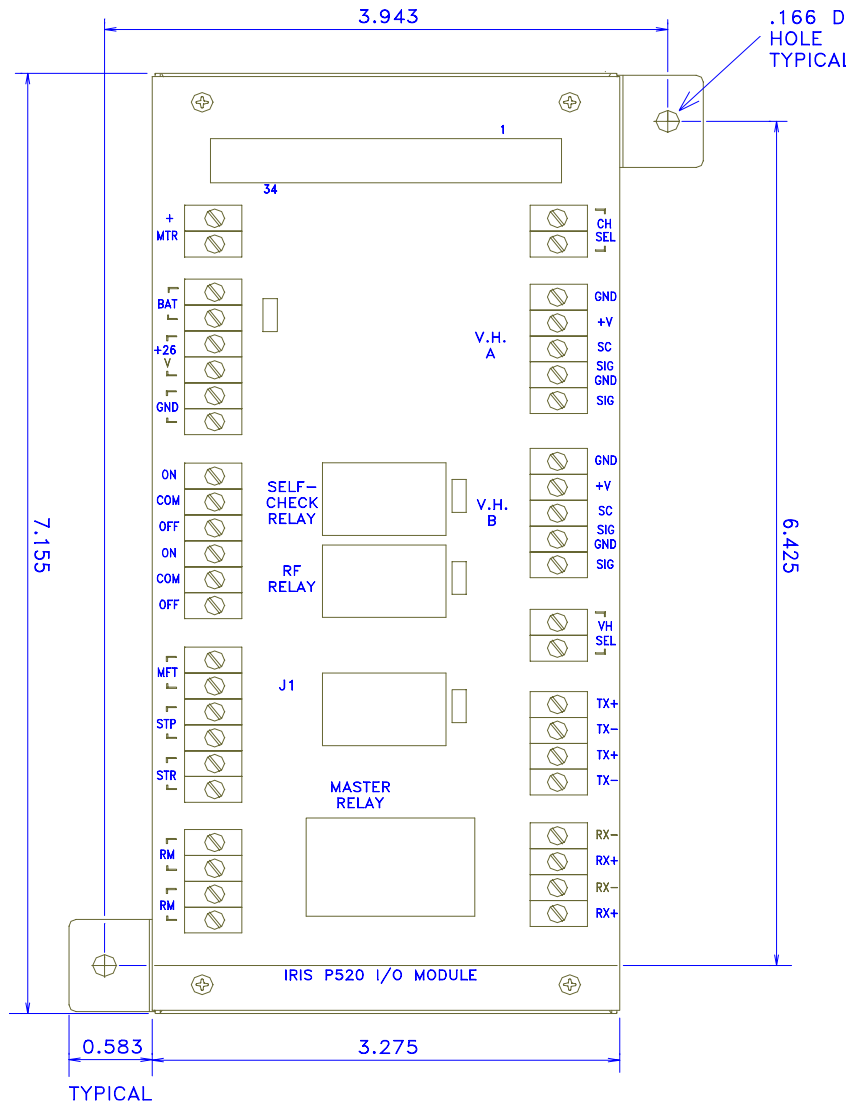

**FIGURE 6 - REMOTE I/O MODULE**

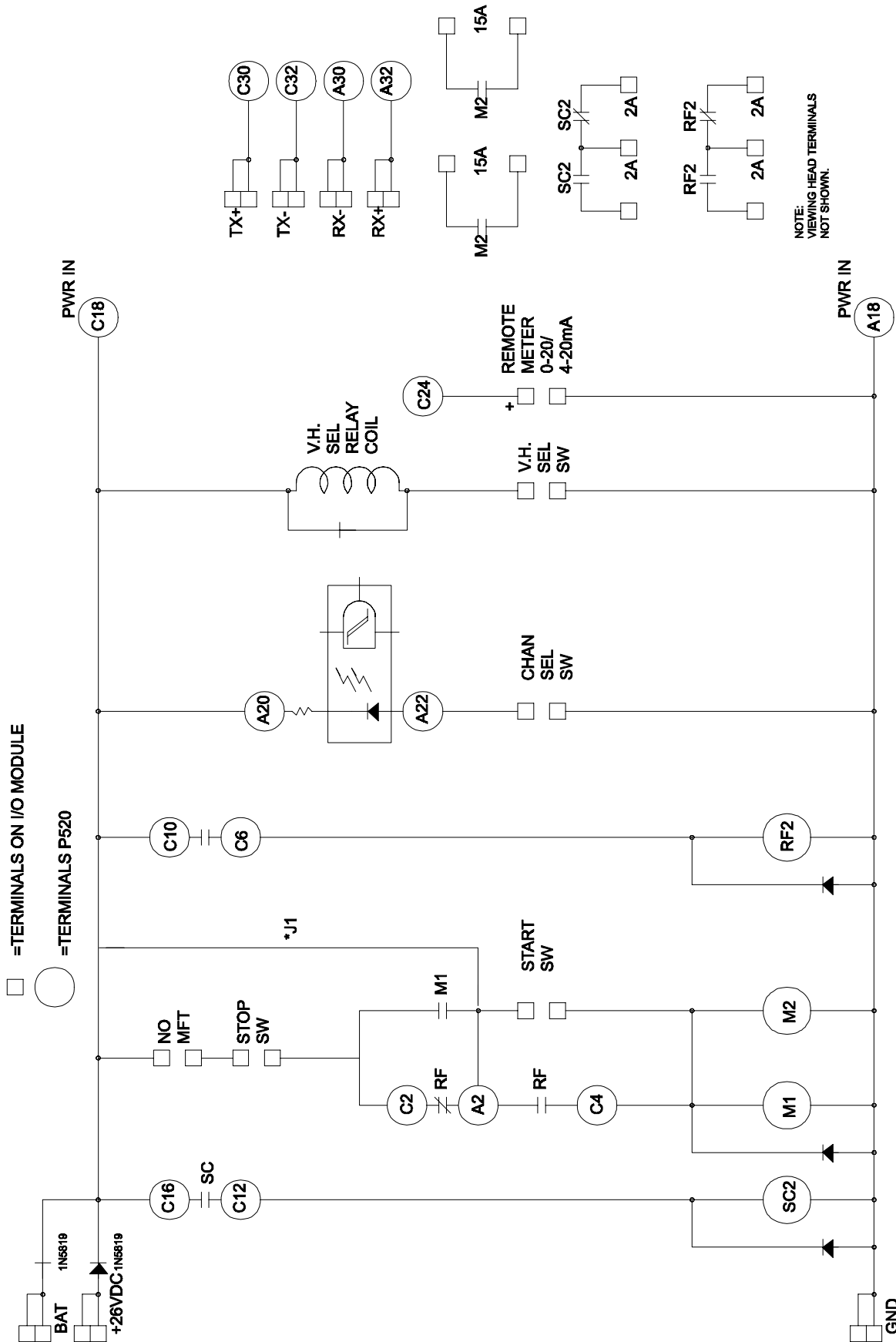

FIGURE 7 - IRIS P520 I/O MODULE SCHEMATIC

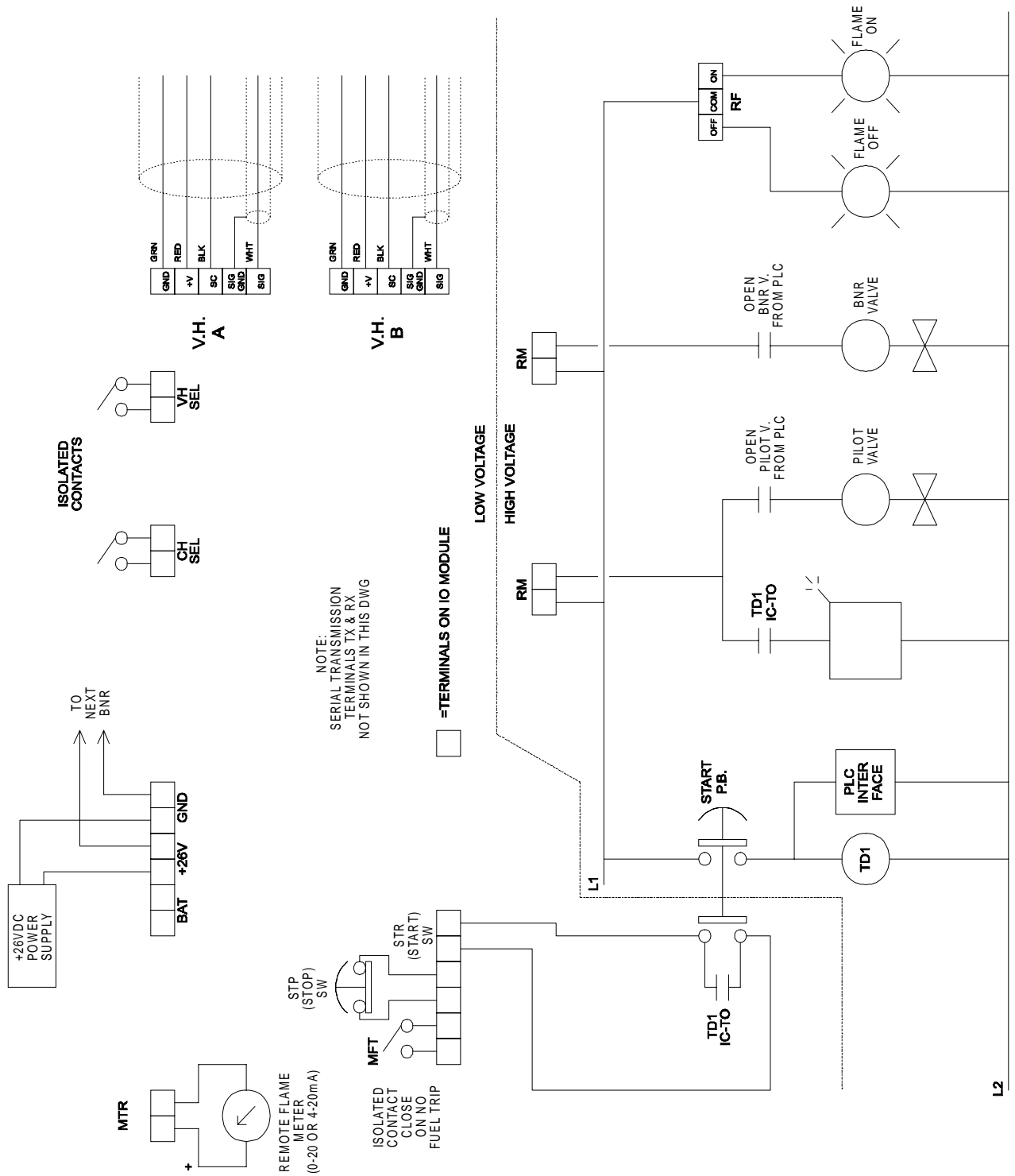

FIGURE 8 - FIELD WIRING TO I/O MODULE

# IRIS MODEL P520 APPLICATION MANUAL

Figure 5 illustrates a half-card frame (19-inch) mounted to a panel with four, male-female 10-32 standoffs. Any number of P520 modules can be mounted this way, using the standard 19-inch card frames.

A rear I/O PCB is used at the rear of the card frame to terminate each P520. A ribbon cable is then used to connect the I/O module, which can be mounted anywhere on the panel. The rear I/O PCB incorpo-

rates a viewing-head switching relay and the ribbon cable receptacle.

The I/O module is illustrated in Figures 6 & 9, and the wiring schematic of this module is provided in Figures 7, 8, & 9. The I/O module provides a master relay (load relay) with two sets of form A contacts rated to 15 Amps, and is designated as M2 in the schematic.

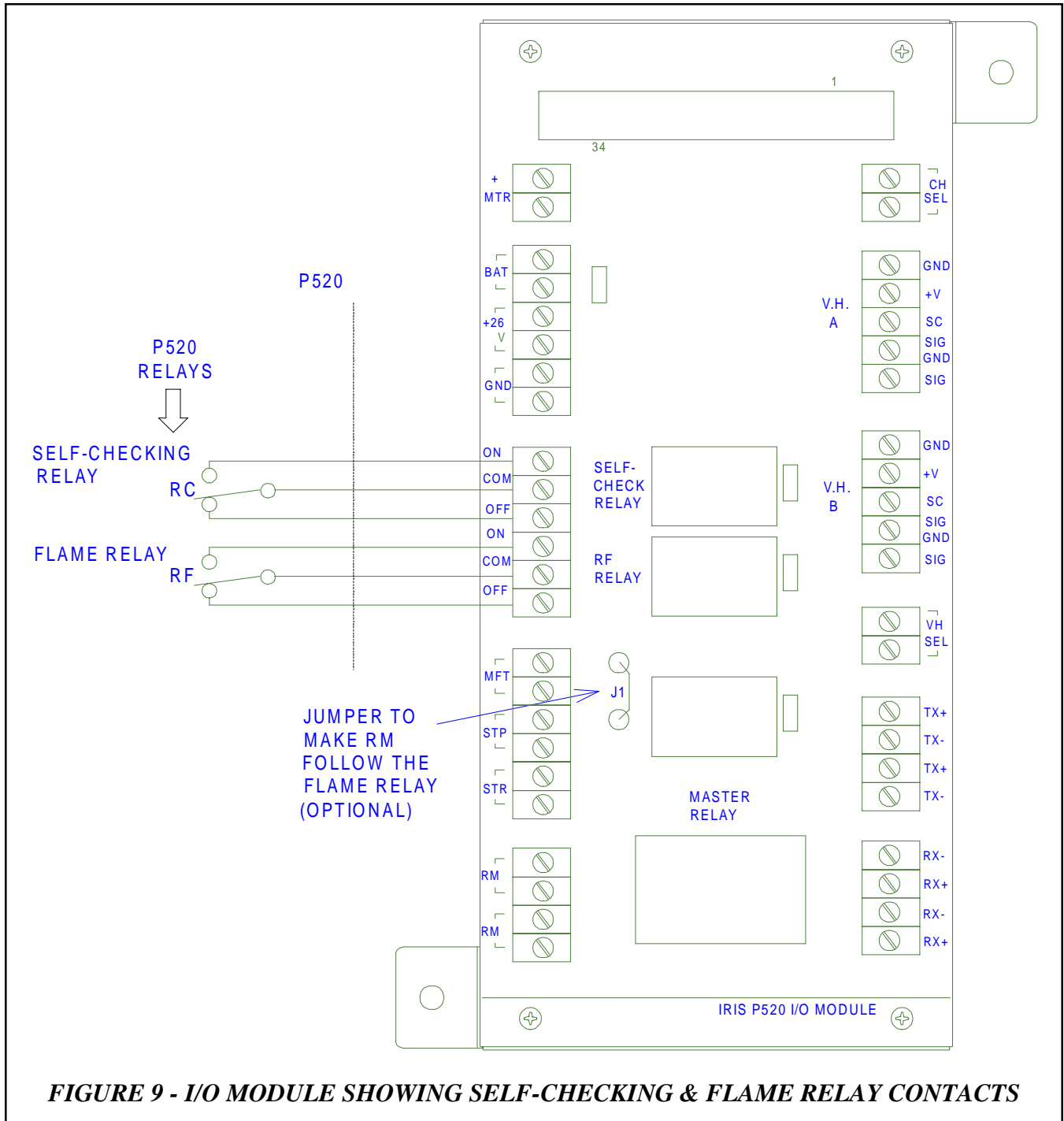

**FIGURE 9 - I/O MODULE SHOWING SELF-CHECKING & FLAME RELAY CONTACTS**

A field wiring diagram is provided in Figure 8.

Note that a “safe-start-check” circuit is used, requiring an auxiliary timer (see section **BASIC BURNER START CIRCUIT**). The same sequence of operations prevails, except that the RM contact is now part of this I/O module (M1 and M2 in the schematic). Refer to section **The sequence of operations for BASIC BURNER START CIRCUIT**.

Note on the module schematic (Figure 9) that the RM relay can be converted to follow the

by installing a jumper from 26 VDC to the top of the start switch (solder a bus wire between the pads marked J1). This would be done for applications not requiring a master relay, and where the RF contacts must switch higher currents.

Figure 9 illustrates the relationship of the P520 internal relays with respect to the actual terminals on the I/O module. Essentially, the P520 self-checking relay and flame relay contacts are repeated on the I/O module by using another set of relays. This is done so that load currents will not have to be carried by the ribbon cable which is composed of relatively small-gauge wire. As mentioned before, the jumper J1 can be used to make more flame relay contacts available, assuming you are not going to use the master relay for the “safe-start-check” function described previously.

## **APPROVALS**

The P520 and viewing heads have Factory Mutual (FM) Approval for Combustion Safety; Canadian Standards Association (CSA) Certification, and National Recognized Testing Laboratories (NRTL) Listing.

## **POWERING UP THE P520**

Once the power is connected (26 VDC) to the plug-in connector, the P520 will be operational. There is no ON/OFF switch on the P520; the moment it is powered on, it will reset and start up. The self-checking light will start blinking, and one of the channel LEDs (A or B) will light (A will be ON if the channel select input at the plug-in connector is de-energized). Make sure the voltage is 24 to 26 VDC. The P520 will be reset when the power is turned on; however, the power

must be a step function (i.e., the power must be applied abruptly) for this reset to work properly.

The P520 has been designed to deal with any foreseeable power failure or anomaly.

For example: if the power goes off while you are in the process of storing a set point (either from the front panel or from the remote, host computer), the internal power monitor circuit will signal the P520 processor to complete the store function before shutting down in an orderly manner. This prevents bogus numbers from being stored and protects existing data in the EEPROM (Electrically Erasable Programmable Read Only Memory) from corruption, and is facilitated by a special internal power supply that holds a charge (like a battery) just long enough to allow the processor to do its job before going dead.

This internal circuit monitors the 26 VDC power feeding the P520, and when the voltage drops to about 19 volts, the processor shuts down, the program stops running, and the self-checking function ceases (the self-checking relay de-energizes). The blinking, SELF-CHECK O.K. light on the front panel will go out, and the flame relay will de-energize. Please note that the S509 and S512 viewing heads will shut down at about 17.0 volts; these heads have their own power-monitoring capability, and will shut down on their own independent of the signal processor.

When the power feeding the P520 exceeds 19 volts, the processor starts the program again. The SELF-CHECK O.K. light will start blinking, and the self-check relay will energize. If flame is present and a S509 or S512 viewing head is being used, the flame signal will not come back on until the power reaches 21.5 volts. This can cause a lockout condition if the viewing head turns on during the dark period (defined by the periodic self-check signal going to the viewing head each second), requiring a manual reset of the P520. There is a 20 per cent probability that a lockout will occur because of the duty cycle of the self-check function (200 mSEC on and 800 mSEC off). The other viewing heads (the S506, S511) do not in-

corporate the power-monitoring shutdown function, and will not cause a lockout condition.

These design precautions ensure that there will never be an unsafe situation created by abnormal line power (115 VAC) conditions. The 26 VDC power is very unlikely to come on gradually, but, if this did occur, the P520 would not get a proper reset. So, there is another function in the processor (used in the P520), implemented by circuitry and software, that causes the P520 to appear dead (i.e., the front panel will be dark) and to stay this way until the power is recycled in an abrupt manner, initiating the reset.

## SET POINTS

There are 10 set points stored in memory in the P520, divided into two equal sets, A and B.

SET POINT	DISPLAY	NUMBER
FLAME ON	4 DIGIT NUMBER	0001-2999
FLAME OFF	4 DIGIT NUMBER	0000-2999
GAIN SET	2 DIGIT NUMBER	00-99
F.F.R.T.	1 DIGIT NUMBER	1,2 OR 3
TIME DELAY ON	1 DIGIT NUMBER	0,1,2 OR 3

**FIGURE 10 - SET POINTS**

To see what the current set points are, simply push the desired button. For instance, to determine the current FLAME ON set point, press the FLAME ON button. The set point will be displayed on the readout for about four seconds, then return to normal (likewise for all set points). The set points displayed will be for the channel that is active, which is indicated by a steady illumination of push-button A or B.

To see the other channel set points, first select the channel (A or B), then press the desired set point button.

For example: if channel A is already ON, indicating it is functional, and B is pressed, A will go out and B will proceed to blink slowly, indicating that further action is required. If A is already

ON and A is pressed, it will stay steady ON and start to blink rapidly *after* a set point button is pressed.

In all cases, A or B will rapidly blink after the set point is selected. This action alerts the user that the current display is no longer that of the flame signal, and further action is required.

The fact that A or B is already on has nothing to do with the process of viewing the current set points, except that you do not have to select the channel if it is already on. The steady illumination of A or B indicates which channel is functionally active, and is selected at the rear PCB marked CHAN SEL.

At any time, you can press the reset button causing the P520 to go back to its normal operating condition. The reset button is also used for resetting the lockout condition as explained in the section **SELF-CHECKING FUNCTION**.

## CHANGING SET POINTS

Changing any of the five set points is easy. Simply bring up the desired set point and change it using the UP or DOWN arrow buttons. When the desired number is displayed, press the STORE button. When the set point is stored, four dashes are displayed momentarily, indicating that the selected number was stored into the EEPROM. Illogical settings cannot be made; so, if four "E's" are displayed when pushing STORE P.B., then an error was made when selecting the set points. For instance, selecting a *flame out* set point that is equal to or greater than the *flame on* set point will result in this error indication.

As well, the set points can be selected remotely through the serial communication port using a host computer – explained in greater detail later in this manual.

## FLAME FAILURE RESPONSE TIME (F.F.R.T.)

The flame failure response time, or F.F.R.T., is defined as the time it takes for the flame relay to de-energize after the flame signal (from the viewing head) drops out. This time delay is programmable

from both the front panel of the P520 and a remote, host computer. Only three settings are possible: one, two and three seconds.

The maximum time delay is limited to three seconds in compliance with the FM (Factory Mutual) limit of the F.F.R.T. to not more than four seconds.

The P520 decision-making process occurs on a periodic basis, and the decision to start a F.F.R.T. time delay before de-energizing the flame relay is initiated every second in step with the sampling rate of the flame signal. This means that the actual flame out condition (i.e., drop-out of the flame signal from the viewing head) will, in all probability, occur during the sampling period that causes the actual F.F.R.T. to be greater than the set time.

For example: suppose the signal from the viewing head drops out *immediately after* a sampling from the P520, and the sampling perceives flame to be present. If the F.F.R.T. set point is set for three seconds, there will be an actual time delay of nearly four seconds. In other words, the actual F.F.R.T. will be the current set-point time, plus an additional amount of time not exceeding one second, depending upon when the flame signal from the viewing head drops out.

FLAME ON	FLAME OFF	GAIN SET	FFRT	TIME DEL ON
X	X	X		
			X	X
X	X	X		

**FIGURE 11 -REMOTE METER ANALOG OUTPUT**

## 4-20mA REMOTE OUTPUT

The standard remote meter output has a 0-20mA range and is designed to drive remote meters, as explained earlier in this manual. You can convert this output to a 4-20mA range, as follows:

Press the front panel push-buttons (indicated in the table below) while holding down both the up arrow and down arrow buttons.

Press all in each row together (i.e., three in the first row, two in the second row, and three in the last row).

Doing this toggles the function back and forth between the 0-20mA and 4-20mA ranges.

The change will be verified by four dashes “- - - -” and “4-20” momentarily displayed. If the module is programmed for the 4-20mA range, “4-20” will be displayed; toggling back to the 0-20mA range will again cause four dashes to appear upon power-up of the unit. The factory default settings are 4-20.

One thing to consider when feeding the 4-20mA signal to a remote computer or DCS, is that there is no isolation between the P520 ground and the remote system ground. If there is a ground potential difference between the two systems, then there could be serious noise and performance problems. You will not encounter this problem when using a remote meter by itself, because it will not be tied into another electrical system (will not be sharing grounds).

The bargraph reading on the front panel will not be affected by this change to 4-20mA output. It will remain the same as before (i.e., go to zero on *no signal detected*). The 4-20mA output will still perform the same way on the high end (i.e., on a strong signal, it will saturate at the same level, slightly above 22mA).

Specifications for the analog current output signal are provided in **SPECIFICATIONS**, Figure 18.

## INSTALLATION OF VIEWING HEAD

Before beginning the actual installation, determine the best location for mounting the viewing head based upon the following factors:

**VIEWING HEAD CROSS-REFERENCE**

<b>OLD NUMBER</b>	<b>NEW NUMBER</b>
S506	S506
IRX2S	S509
IRGS	S511
IRS	S512

**FIGURE 12 - VIEWING HEAD CROSS-REFERENCE TABLE**

**PRESSURE**

The viewing head lens will withstand 5 psi. If the lens assembly is exposed to greater than 5 psi through the sight pipe, then an isolation unit must be used. An IRIS isolation unit with purge air entrance is available as an accessory.

**TEMPERATURE**

The viewing head will withstand an ambient temperature to 80°C (176°F). However, **the case temperature of the housing must not exceed 60°C (140°F)**. Purge air will help reduce conducted heat through the sight pipe to flange (a plastic nipple will also help), but direct radiation can cause the housing case temperature to exceed limits. If the ambient heat (direct radiation) is excessive, then a fiber optic extension should be used (please refer to the IRIS Model 500 Fiber Optic System manual). This system is composed of a viewing head, a fiber optic assembly, and an amplifier module.

The model S5xx series of viewing heads have in place a sensor for sensing the internal temperature of the head. To access the reading of the viewing head temperature, press the “Reset” and the “Down” arrow key at the same time. The temperature reading will be displayed in the four-digit readout. The reading (indicated in °C) will disappear and the normal reading will continue after several seconds.

**VIBRATION**

Do not install the viewing head where it could be subject to vibration. A vibrating viewing head (flicker type) can simulate flame when viewing a glowing background. Provide an antivibration mount if excessive vibrations are present.

**CLEARANCE**

Make sure there will be sufficient room to remove the housing for servicing (see Figure 20).

**SIGHTING OF THE VIEWING HEAD**

In general, the sighting of the viewing head should be parallel to the center line of the burner in the direction of the burner flame. This applies to both the UV type as well as the flicker type. Flicker type detectors respond to the high frequency flicker of the flame; so, in order to achieve maximum discrimination between burners, the near portion of the primary combustion zone should be favoured – meaning the sight pipe should be mounted as close as possible to the burner center line. The sight pipe should be aimed at the root of the flame, which radiates the most intense, high-frequency flicker energy. Sighting *along* the flame rather than *across* it permits the detector to view a greater depth of the flame root, obtaining better response (see Figure 22).

When sighting for a UV viewing head, you must aim for the UV zone, which is usually at the very first part of the flame root. UV radiation from most flames is restricted to a narrow region: it starts very close to the burner nozzle and does not extend out very far from the burner nozzle. You may have to angle the sighting inward toward the flame root, as shown in Figure 23.

The effectiveness of the sighting will depend upon both the type of viewing head as well as the fuel. UV flame detection works fine on natural gas, but will cause problems with fuels that either block or absorb the UV signal.

For example: in a pulverized coal burner, there can be unburned fuel at the burner nozzle, creating a “skirt” that blocks the UV radiation coming from the flame. Heavy oil burners can also cause prob-

lems with UV-type flame detection, particularly if the fuel has a high sulfur content, which will absorb the UV radiation.

**MULTIBURNER REQUIREMENTS**

Multiburner installations require discrimination. This means that, in spite of the brightness of other flames in the furnace, the flame relay must respond only to the presence or absence of the flame produced by the burner that it is monitoring. Not every viewing head can be positioned so that its line of sight does not intercept flames from other burners – a situation that occurs in multi-level, opposed fired furnaces where the burners face each other.

In such cases, the sighting angle is set up as described above, with the viewing head sighting along the flame directly into the flame root. If an opposing or adjacent burner flame falls within the line of sight of the viewing head, it may be effectively tuned out by setting the FLAME OFF set point high enough to ignore this background. If discrimination cannot be achieved by doing this, it is recommended that the filter switch in the viewing head (except the S506 UV, which doesn't have one) be switched to a higher position. This reduces the low-frequency flicker reaching the detector so that the set points can be adjusted to affect flame discrimination. The four cutoff frequencies are outlined in Figure 13.

S511 & S512		S550 & s552	
LL	36Hz	1	16Hz
L	71Hz	2	24Hz
M	105Hz	3	33Hz
H	186Hz	4	52Hz
		5	75Hz
		6	100Hz
		7	155Hz
		8	215Hz

**FIGURE 13 - CUTOFF FREQUENCIES**

A higher filter position creates a narrower bandwidth, causing an overall reduction in the flame signal; however, the ratio of flame ON to flame OFF may be im-

proved by properly setting this four-position filter. Note the readings on the four-digit display when making these adjustments. The four-digit number is an absolute indication of signal strength, and is not affected by changing the gain of the analog output.

**MULTIPLE VIEWING HEADS**

This system can accommodate the parallel operation of two viewing heads with one signal processor. The flame signals will be additive, possibly requiring a lower sensitivity setting. A word of caution about this type of operation: the unwanted background with the burner flame out will *also* be additive, possibly causing a discrimination problem in multiburner applications.

Note: The 55x-series viewing heads cannot be wired in parallel.

Another variation is to switch the flame signal ON and OFF from each viewing head.

For example: one viewing head can be used for the igniter, and the other for the main burner. While proving flame from the igniter, the main burner signal circuit can be opened, leaving only the igniter viewing head signal to be read. And, when proving flame from the main burner, the igniter signal circuit can be broken.

We recommend that only the flame signal from each viewing head be switched, leaving the other connections to the viewing head intact (the one exception would be the S506 UV head). Both the flame signal and shutter drive circuits should be switched so that when the head is not being used, the shutter is not switched on and off. This was done in the design of the rear mother board (see section **WIRING REAR PCB**).

Note that both the SIG and SIG GND circuits are switched. However, this can cause a lockout condition if the transfer of the viewing heads is done during the dark period. This problem can be avoided by changing channels when switching heads (i.e., by wiring the two terminal blocks V.H. SEL and CHAN SEL together in parallel). This will inform the P520 that the viewing heads are being transferred, and the pulses counted during the dark period will be ignored.

### DETERMINING SIGHT PIPE SIZE

In order to determine the proper sight pipe, it is important to understand how the viewing head “views” the flame. The viewing head employs a plano-convex lens in front of the photodetector that focuses the flame radiation on the surface of the detector. The active photodetector element is quite small, and its diameter and the focal length of the lens determines the angle of view. For the S509 viewing head, this angle of view is about 2.8 degrees. For the S512, the angle is slightly less.

To understand what this means, imagine a circular target of flame radiation, one inch in diameter, 24 inches away from the lens: this is the maximum field of view the detector sees. In other words, a one-inch diameter sight pipe two feet long will allow maximum signal to be detected. A two-inch diameter sight pipe four feet long presents the same target. Actually, a one-inch target three feet away causes an immeasurable signal attenuation, so you can use a two-inch diameter pipe up to six feet long, with no signal attenuation.

The angle of view for the S511 viewing head is 1.1 degrees. This translates into a one-inch, circular target 52 inches away from the lens. In other words, a one-inch diameter sight pipe four feet long (or, a two-inch diameter sight pipe eight feet long) will allow maximum signal to be detected.

For a detailed explanation of how the angle of view is derived, refer to section **ANGLE OF VIEW OF VIEWING HEAD**.

If a long sight pipe is required, then we recommend that a swivel mount be used to overcome any optical misalignment that might be present (see Figure 25). In this way, the flame signal can be optimized by adjusting the viewing head to the target at the end of the pipe.

### SELECTING THE PIPE

We recommend a black iron pipe to provide reliable flame sensing. The viewing head is tapped for a one-inch *national pipe thread* (NPT) threaded pipe. Any diameter sighting-pipe larger than one inch will require a reducer coupling or swivel mount (see Figure 25).

### MOUNTING HOLE

Cut a hole for the sight pipe in the burner front windbox at the selected location. The hole should be large enough in diameter to allow adjustment of the sighting angle. If register vanes interfere with the desired line of sight, trim the interfering vanes to ensure an unobstructed view of the flame.

### MOUNTING OF SIGHT PIPE

After cutting the pipe to the desired length, thread one end of the pipe to fit the viewing head flange or required coupling (see Figure 25). Insert the other end of the pipe into the mounting hole, align the pipe to the desired sighting angle, and tack weld it in place to allow further sighting adjustments. Make sure the tack weld will support the weight of the detector when it is installed. Once the final position has been determined, weld the sight pipe in place.

### INSTALLING THE VIEWING HEAD

The viewing-head flange screws directly onto a one-inch NPT threaded pipe (see Figure 25). Use a crescent wrench to tighten the flange onto the sight pipe.

### PURGE AIR

Use a flexible air supply line, allowing repositioning of the sight pipe until the permanent detector position has been verified. A continuous flow of air must be maintained in order to keep the head cool and the sight pipe clean. We recommend that at least three CFM at approximately eight inches of water column above windbox pressure be provided for each viewing head. The air supply must be clean, free from oil and water, and preferably cool.

### SET UP AND ADJUSTMENT PROCEDURES

Multiburner applications require the most care in adjustments to ensure proper flame out operation under worst-case conditions (refer to previous section **MULTIBURNER REQUIREMENTS**). These same procedures can be followed for single-burner applications, even though the adjustment refinements described here may not be necessary.

There are two, basic worst-case conditions in a multiburner installation:

One is the initial light off of other burners after the first burner has been established (particularly if the established burner, or burners, has a flame envelope that overlaps the trial burner sighting). If there is a flame out or ignition failure of this burner (or its igniter) during this startup sequence, the flame monitor must detect this condition – meaning that it must discriminate between the lack of flame and the background flame of the established burner. This would represent “flame discrimination under low fire conditions.”

Second would be when the fired unit is in a high fire condition (i.e., all burners are firing at maximum rate, when suddenly one burner flames out – possibly because of a clogged oil gun or some other type of fuel disruption). This is also a dangerous condition, particularly for two- to four-burner installations. The flame monitor must detect this flamed out burner so the fuel valve (safety shutoff valve) supplying this burner will close. This means that the flame OFF threshold for this flame monitor must be set above the signal level produced by the other burners that are in a high-fire condition. This represents “flame discrimination under high fire conditions.”

## **SIGHTING ADJUSTMENT**

Before making definitive settings (i.e., establishing the set points) for flame ON/OFF, you must optimize the sighting of the viewing head. This can be done if a swivel joint is used at the end of the sight pipe and the diameter of the sight pipe is large enough to allow a range of angles to be viewed (see section **ANGLE OF VIEW OF VIEWING HEAD**).

Optimizing the sighting can be confusing, because of all the variables involved. Different fuels and burners, as well as the different viewing heads, will all affect the sighting process.

As a general rule, the sighting of the S506 viewing head is more likely to be “line-of-sight” than the S512 infrared flicker viewing head, which will read flame signals bouncing off the side of the sight pipe and other “reflectors.” Sometimes, the reading with the IR detectors can be greater with a reflective signal than the direct line of sight. The UV viewing head,

on the other hand, will have to be aimed at the part of flame having the highest concentration of UV which is usually at the root of the flame (at the throat of the burner) and in a very narrow range.

The angle of view of the S506 is somewhat wider than the S512 or S509, but this does not offset the fact that the UV radiation present is very narrow. This is not true, however, for low NOx gas burners; the UV is usually much less in intensity with this type of burner, and spreads out in front of the burner, getting readings from all over the furnace when many burners are on. This is particularly true when fuel gas recirculation is used.

Another factor to consider when aiming the viewing heads is the load condition of the boiler. The flames from a burner can be radically varied at different loads – one of the reasons for trying to select a sighting that will minimize the changing flame at different loads. If the flame front moves farther away at higher loads, then a sighting parallel to the burner axis will be best. A large-diameter sight pipe with a swivel mount is recommended for all installations on large, multiburner boilers. (Refer to Figure 25.)

## **INITIAL SET UP**

- A. The initial settings for the P520 signal processor should be as follows:
1. F.F.R.T. (Time Delay Off) to 3 SEC.
  2. GAIN SET to 25.
  3. TIME DELAY ON to 0.
  4. FLAME ON to 200.
  5. FLAME OFF to 100.

The above settings will be satisfactory for most applications, but are used only as a starting point. So many variables can affect the readings that it is impossible to catalogue all the settings, and each viewing head has its own characteristics for the different types of fuels and burners. We recommend that you become knowledgeable about the characteristics of the different viewing head models

available before applying them to a particular application. Detailed descriptions of the viewing heads are provided in this manual, and the **VIEWING HEAD APPLICATION TABLES** (Figure 16) are a useful summary of the viewing heads and their response to different fuels.

- B.** The initial settings for the flicker type viewing heads (S509, S511, S512) should be as follows:
1. Set filter switch to LL position.
  2. *Gain potentiometers* (POTS) full clockwise (these are 25-turn potentiometers – a slight clicking sound will be heard when the POT is maximum clockwise). There are two POTS on the S509: one for the Si channel, and one for the PbS channel. If the fuel is natural gas, turn the Si channel off (POT full counter clockwise). Refer to section **S509 VIEWING HEAD**.
- C.** There are no initial settings for the S506 UV viewing head. It is important that this viewing head be properly aimed to pick up the maximum signal, as described in the previous section.

### ADJUSTING SET POINTS

Before adjusting the set points, take readings with the P520 on the two worst-case conditions described (see section **SET UP AND ADJUSTMENT PROCEDURES**). Write down the readings for the burner ON and OFF (with other burners on) under **low** load conditions, and then the readings for the burner ON and OFF under **high** load conditions.

There must be a definitive ratio between the readings for burner ON and burner OFF. This ratio can be defined by using the *lowest* reading for burner ON from both of the load conditions, and the *highest* reading for burner OFF from both of the load conditions. If the readings are 2:1 or more (BNR ON to BNR OFF) then there should be no problem discriminating between burners.

A good balance for the set points would be:

$$\text{ON}_{\text{SET POINT}} = .75A + .25B$$

$$\text{OFF}_{\text{SET POINT}} = .25A + .75B$$

where A is the lowest burner ON reading, and B is the highest burner OFF reading.

Actually, a smaller ratio will work, as long as the lowest BNR ON reading and the highest BNR OFF reading never deteriorates to the point the former is equal to or less than the latter. In other words, A must always be greater than B. Using a safety factor of 2:1 will allow for flame signal changes that probably will occur over a period of time.

#### **A. FOR FLICKER TYPE VIEWING HEADS:**

If unable to achieve discrimination from background signals (for models S509, S511 and S512 viewing heads), remove the viewing head housing from the flange and place the filter switch to the next highest position L. Reinstall the viewing head and take another set of readings. Note: the filter switch should be moved only one position at a time for each set of readings. Refer to section **MULTIBURNER REQUIREMENTS**.

#### **B. FOR THE S509 VIEWING HEAD:**

If you are still unable to achieve satisfactory flame OFF operation, remove the viewing head and turn the Si channel off by turning the Si POT at least 30 turns counter clockwise. The signal level will now be lower because only the PbS detector is being used, so the set points must be re-evaluated. If you are using an S511 viewing head and not achieving successful discrimination, it is likely due to the *automatic gain control* (AGC) action (see sections on the viewing heads for a detailed explanation of this problem). When using the PbS only or the S506 (same for the S512), **make sure the signal is not saturating, particularly at high load conditions.** (Refer to section **ORIFICING**.)

- C. For the S550, the S552 and the S556, see corresponding manual(s).

## TROUBLESHOOTING GUIDE

### A. NO FLAME SIGNAL and NO DISPLAY

1. Check wiring (refer to section **WIRING REAR PCB**).
2. Check the voltage at PWR IN terminals with a volt meter. It should measure approximately 26 VDC. If not, check the power supply and wiring, or replace the power supply.
3. If 26 VDC is measured, check F1 on the P520 main PCB (this is a .75 Amp, 20mm fuse).

**Note:** In order to change this fuse, the back plate (which is fastened to the side extrusions with four M2.5 screws) must be removed. Use a small Phillips screw driver to remove the screws, then slide out the top cover. Very carefully disconnect the ribbon cable from the main PCB by ejecting it with the two levers on the connector header, and slide out the PCB. The fuses F1 and F2 are located toward the rear of the PCB (near the output relays).

### B. DIGITAL DISPLAY IS SHOWING 0000 AND NO FLAME SIGNAL

1. Remove the connector from the viewing head, and check the wiring (refer to the viewing head wiring diagram, Figures 2 & 3.)
2. Using a volt meter, check at viewing head terminals on rear PCB for 26 VDC across +V and PWR GND. If the voltage is low, check the power supply. If the voltage is zero, check fuse F2 on the main PCB (this is a .25 Amp, 20 mm fuse).

3. If the voltage measures 26 VDC at viewing head terminals, check the voltage at pins four (26 VDC) and five (PWR GND) of the viewing head connector. If the voltage is zero, check the wiring and/or replace the viewing head cable. If 26 VDC is measured, then the viewing head may be defective, and should be replaced.

### C. FLAME SIGNAL SHOWS ON DISPLAY; FLAME ON RELAY AND LIGHT ARE OFF.

1. The viewing head is incorrectly wired, or defective (see B, above).
2. The set point values for flame ON are incorrect.

### D. FLAME SIGNAL SHOWS ON ANALOG BARGRAPH DISPLAY; FLAME ON LIGHT IS OFF; LOCK-OUT LIGHT IS ON.

1. The viewing head may be defective.
2. There may be a noise or grounding problem (see **NOISE INTERFERENCE AND GROUNDING**, following section).
3. Press RESET button on front panel.

### E. 1-9 LED STAYS ON

1. There may be a noise or grounding problem (see D2, above).
2. The viewing head may be defective.

### F. FRONT PANEL BUTTONS DO NOT RESPOND.

1. The P520 may be in remote operation mode.

## NOISE INTERFERENCE AND GROUNDING

The viewing head terminals marked GND on the rear backplane PCB are wired to pin 5 on the viewing

head plug (see section **WIRING OF VIEWING HEAD**). Pin 5 of the viewing head male receptacle has an internal tab that grounds this connection to the viewing head housing. Terminal GND connects to the chassis ground of the P520. This ground is made through the internal PCB to the metal base of the module.

It is important that the AC power be a grounded source (i.e., GND going to plant ground – refer to section **POWER SUPPLY**). Interference problems can occur if the power supply chassis and the P520 chassis are at a different ground potential than the viewing head housing, which will be at a ground potential associated with the burner front. In these situations, the IRIS flame monitor effectively supplies a plant ground between the burner front and the panel enclosure. If there is a large potential difference between these points, considerable current can flow through the viewing head cable, which can, in turn, damage the P520 signal processor or the associated power supply.

If there is a voltage difference between the viewing head and the sight pipe, then you should use a non-conductive, one-inch plastic nipple between the sight pipe and the viewing head mounting flange. This voltage difference can be easily measured by disconnecting the viewing head from the mounting flange so that there is no continuity between the viewing head and the boiler front.

**Note:** *Use a battery operated multimeter on a high voltage AC range for making this measurement.*

This measurement should be made under various conditions (i.e., during the sequencing of the igniter and burner).

In addition to using the isolated nipple for the viewing head flange, you must use a nonconductive rubber or plastic hose for the purge air (there is a 1/2-inch NPT pipe thread on the flange). This will prevent the current from flowing through the IRIS cable (power ground) back to the P520.

Another source of interference is from high-voltage spark igniters. A high voltage of 6 KV or more is usually supplied by a step-up autotransformer and,

not being isolated from the power line, it can cause interference, particularly if there are grounding problems. The usual problem occurs when the transformer is energized, resulting in a bogus flame signal. The problem is not caused by the spark across the gap, but by radiation from the high-voltage wiring feeding the spark gap. It is the secondary wiring of the transformer (high-voltage AC) that causes this interference – both the insulated wire to the spark gap, as well as the ground return. This circuit loop acts like a giant antenna. Also, this type of transformer can cause a ground problem because it is an autotransformer, and because it is not isolated from the power line. The high-voltage current to the igniter must return to the transformer through the plant ground, which is the conductive metal of the plant.

The solution to these problems is to locate the ignition transformer as close as possible to the igniter, and away from the P520 card frame and power supply. The shorter the secondary wire run, the better. Also, the ground return path should be examined. Is the igniter properly grounded, and is this a good plant ground? Plus, you should examine the grounding of the transformer case: we recommend that there be a good plant ground on the transformer case, and that the transformer be enclosed in a metal enclosure that is also grounded.

Usually, there are no straightforward solutions to electrical interference problems; each will have its own unique causes. However, there are certain precautions or guidelines that you should be aware of. The first thing to check is the grounding of the installation. Make sure the AC power feeding the system is grounded, and that the ground is a bona fide plant ground. And, make sure the proper cable is being used for the viewing head.

**Note:** *Do not use cables that employ foil type shields (aluminum-polyester). We recommend you use the standard IRIS cable that has a braided shield.*

## S506 VIEWING HEAD

The S506 viewing head employs a UV tube that has a spectral response of 185-260nm. It is an inherent pulsing device (i.e., the power supply has been designed so that the tube emits pulses when UV radi-

tion is present). Its output is randomly-spaced pulses, with an average pulse rate proportional to the UV radiation present. The digital count when reading natural gas will be about the same as the S512, and probably will be less when reading a heavy oil flame.

The very narrow spectral response of the UV tube makes this type of detector ideal for discriminating between flame, glowing refractory, and other burners. However, because of its response to only the very short wavelengths, problems can occur because this radiation is easily absorbed and masked by unburned fuel or other impurities in the coal (i.e., with pulverized coal). Sour gas ( $H_2S$ ) will readily absorb these short 200 nm wavelengths, as well as other waste fuels resulting in a dropout of the flame signal. Even standard glass will absorb this wavelength; therefore it is necessary to use a quartz lens with this viewing head.

In general, the S506 viewing head will work well on natural gas flames. It will respond to oil flames, but with a lower signal level. The sighting should be parallel to the axis of the burner and aimed at the foot of the flame. Photographs of gas and oil flames using visual- and UV-sensitive film clearly show that the UV zone is much smaller than the visible zone, and the highest UV intensity occurs near the flame root. In addition, the zone of higher UV intensity does not overlap the same zones of adjacent or opposing burners; so, with proper sighting, discrimination is predictable.

## S506 SELF-CHECKING VIEWING HEAD

The self-checking characteristics of the S506 are implemented by using a shutter that blocks the flame light path every second for 200 milliseconds. The reason for doing this, presumably, is to detect a runaway UV tube. The McGraw Edison-type tube traditionally used for UV flame detection is known to have an avalanche mode (runaway condition) that creates pulses when there is no flame present.

The UV tube used in the S506 is a different type of tube, having an anode and cathode instead of the dual-anode type used by others. This tube also uses

a relatively low voltage for operation, and we have experienced a runaway condition with this tube only once, with a tube that had been subjected to such a significant shock that the electrodes inside were clearly bent.

*Why use self-checking if the tube does not runaway? Because any runaway failure, for any reason, is unacceptable, and self checking monitors all electronic components, from the UV tube to the flame relay.*

Each time the shutter closes, the flame signal is blocked, resulting in a cessation of pulses. This is interpreted by the P520 as a normal condition (no pulses during the dark period) and the flame relay is kept energized. If this does not occur, the P520 will go into a lockout state, causing the flame relay to de-energize (see section **SELF CHECKING FUNCTION**).

## S509 VIEWING HEAD

As explained in the S509 product brochure, this viewing head employs a two-colour photodetector using a “see-through” silicon (Si) front element and a lead sulfide (PbS) back element. It is important to understand how this viewing head operates with respect to different fuels and flame conditions.

The electromagnetic spectrum, or spectral range, for the Si element is 350 nm to 1100 nm; for the PbS element it is 1100 nm to 3000 nm. The Si element will detect all incandescent type flames such as oil, pulverized coal, and most waste fuels. It will *not* see natural gas or propane fuels at all. The PbS element will detect *all* flames, including natural gas and propane.

For this reason, the S509 viewing head will exhibit stronger signals for oil and pulverized coal than for natural gas, providing both the Si and PbS 25-turn POTS are full clockwise (full on). Typical “bright” signals for oil can read as high as 2900 on the digital display, while natural gas may read as high as 2100. For instance, a propane torch two inches away from the viewing head will read 1900. (The above, typical readings are made with the filter switch in the LL position.)

An important characteristic that must be explained is the nonlinearity of the Si channel on “bright” signals. The Si element is a photodiode that is operated in the photovoltaic mode (the diode generates current when exposed to light or radiation). The sensitivity range of this device in this mode is quite large, from nanoamperes to milliamperes – so some means to prevent saturation in the first stage of amplification is required. (The PbS element, on the other hand, has a rather limited dynamic range exhibiting not more than a 15:1 ratio from dark to a bright signal.) In order to prevent saturation, an AGC type circuit is used, so that the DC component or “brightness” signal doesn’t saturate, causing a loss of the AC component or flicker signal. On a “bright” signal, this Si channel is limited, or compressed, so that there is a maximum signal reached that will not be exceeded, no matter how much brighter the signal is.

Another non-linear characteristic can be attributed to both the Si and PbS channels on “bright” signals exhibiting a large AC/DC component, such as an incandescent light source. In this case, the amplifiers downstream of the first stage are in a clipping mode (i.e., approaching 120Hz squarewave) which, even though the signal is AC, has a limiting characteristic. This is indicated on the digital display with a count or signal strength of about 2900. (This is with the filter switch in the LL position; the display will read about 2100 with the filter switch in the H position.) Fortunately, flame signals do not exhibit this large AC/DC component, so the amplifiers downstream play a lesser role with this type of non-linearity (see section **SIGNAL SOURCES**).

However, if it is determined that there is a limiting action taking place (readings on the digital display of 2700 – 3000), and if this is interfering with the ON/OFF ratio, causing a discrimination problem, it can be easily resolved by turning both the Si and PbS 25-turn POTs down. No effect will be noticed until about 10 turns counter clockwise, and we recommend 15 counter clockwise turns on the first try. The digital display must be used for this adjustment to detect when the signal pulls out of a limiting or compressing mode (i.e., when the signal goes below 2700).

### S511 VIEWING HEAD

This viewing head uses a germanium photodiode that has a narrower spectral range (750 nm to 1900 nm) than the lead sulfide cell used in the S509 and S512 viewing heads. It will detect all types of flames, including natural gas and propane.

Being a photodiode, it is operated in the photovoltaic mode – the same as the Si element in the S509. The same type AGC circuit is used, which is inherently nonlinear. If it appears that a limiting action needs correction, the same remedy can be used here as on the S509.

### S512 VIEWING HEAD

The S512 viewing head employs a PbS-only photodetector, and performs in a similar manner as the S509 two-colour model with the Si channel turned off (i.e., Si channel potentiometer turned full counter clockwise).

It has been our experience that, for many applications using the S509, the Si channel is not used; usually, it is turned off. There are two reasons for this, the primary reason being the inherent nonlinearity caused by the AGC in the Si channel. The wide dynamic range of the Si photodetector requires control of the gain of the first amplifier stage. If this were not done, amplifier saturation of the signal would occur on bright flame signals, resulting in the loss of the flicker signal.

The problem occurs because the AGC responds to the brightness of the flame.

For example: when a burner is on, the flame monitor is picking up a strong, bright signal from the root of the flame; when the burner goes out, the flame monitor is reading background flame from other burners. This background flame is less bright, causing the AGC circuit to increase the gain of the amplifier with a consequential reduction in the discrimination ratio (the ratio between the count displayed with flame ON and the count displayed with flame OFF). The AGC nonlinearity is self-defeating, so to

speak, and is the principle reason this Si element is usually turned off.

The other reason is that the Si photodetector will not see propane or natural gas. If this is the main fuel, then you should definitely turn off the Si channel, which cannot contribute to the flame signal from the burner (when it is gas) but can only read background glow – which will certainly cause a discrimination problem.

An important aspect of using the S512 instead of the S509 has to do with linearity. The non-linearity of the Si channel due to the AGC circuit has already been explained. This AGC is used upstream of the 25-turn potentiometer, so you have no control over this action except for the viewing head sighting, or for using orificing to change the amount of signal reaching the photodetector. On the other hand, the PbS channel upstream from its potentiometer is linear for low to medium brightness flames (i.e., no distortion of the flame signal occurs with regard to amplifier saturation (signal clipping) or nonlinear amplification (AGC) as with the Si channel).

However, saturation will occur with the PbS channel on high brightness flames. You can detect this by observing the digital display reading for boiler load conditions as they vary from low to high. If there is not much of a signal increase between low load and high load, then the PbS detector is saturating.

For example: if the burner flame signal on oil reads 1950 under low load conditions, and reads 2000 on high load conditions, you can be sure that the PbS detector is saturating.

To resolve this condition, reduce the signal brightness by orificing (see next section **ORIFICING**). The orifice disc (installed in the flange) is located immediately in front of the lens and will reduce the amount of signal radiation the same way a camera aperture reduces the amount of light.

As mentioned in the previous section on the S509, saturation can occur downstream from the gain adjustment potentiometers because of the signal amplification process. This type of saturation can be detected on the digital display by observing the signal

count. The S509 will be completely saturated at a count of 2800 – 3000. Saturation begins (waveform just starts to clip) at a count of 2100. This threshold is somewhat dependent upon the flicker frequencies and their distribution, but for the lower frequencies (up to 200 Hz) the count of 2100 can be taken as the threshold. This amplifier type saturation usually will not occur with the S512 viewing head when reading actual flames. It can occur when reading artificial signal sources, such as incandescent and fluorescent lamps, because of the large AC/DC component. It should be noted that amplifier type saturation is not harmful per se, but saturation of the photodetector caused by high brightness flames can be.

You cannot control the nonlinearity caused by the AGC action of the Si channel on the S509, but with the Si channel turned off you can control the linearity of the PbS channel by observing the count on the digital display, and reducing the gain when necessary by orificing. Saturation of the PbS detector can only be corrected by orificing; turning down the gain adjustment potentiometer will not help, because it is the PbS cell upstream that is the cause.

Another nonlinearity of the PbS detector that should be noted has to do with the signal sensitivity and temperature. The PbS-type detector becomes less sensitive with increasing temperature.

For example: the sensitivity or signal will drop to one half with an increase in temperature from 25°C to 50°C. A further increase in sensitivity will occur above 50°C. This is the reason for the 60°C operating temperature limitation on the viewing head. This characteristic is inherent in all PbS detectors, but should not cause a problem with respect to flame monitoring and discrimination. The signal level will be stable once a temperature equilibrium has been reached.

This sensitivity-versus-temperature characteristic is another reason why the PbS cell should not be exposed to high brightness flames. The radiation of the flame is focused on the PbS element, causing its temperature to rise, reducing the displayed count. This reduction in output with increased flame intensity is

another form of saturation. Also, the exposure to elevated temperatures over a period of time causes an aging process resulting in a change of the dark resistance of the PbS element, and a loss of sensitivity.

**To reiterate:** The nonlinearity of the Si channel caused by the AGC action has been a major contributor to discrimination problems. The background will always be less intense, because it is further away (less by the square of the distance). Being less intense means it receives more amplification (AGC action) causing a worse discrimination ratio (the ratio of flame ON to flame OFF).

The PbS detector (S512) is linear up to the point saturation begins. Saturation will occur on bright flame signals. A reading of 1800 or more is an indication that the PbS cell is saturating. **Only orificing can correct this.**

**Remember:** The S512 will read all fuels, propane and natural gas, pulverized coal, light and heavy oil, and all waste fuels. The S509 performs in a similar manner to the S512 by turning the Si channel off.

**ORIFICING**

Orificing the viewing head sight path will greatly improve performance in many applications, particularly with regard to discrimination between flames. The flame signal or radiation intensity can be sufficiently great that the IR type photodetectors (PbS) will be completely saturated. This will be true with large power utility boilers, where the burners are very large and relatively close to each other. If you cannot look at the flame with the naked eye without it hurting, then orificing should be used. This test works for incandescent type flames, such as oil and coal, but will not be valid for natural gas flames.

Orificing will help improve the discrimination characteristics for UV-type viewing heads as well as the solid-state flicker types. The UV tube in the S506 is not likely to saturate; however, if the count is over 1500, orificing will definitely improve the discrimination ratio.

An orifice disc is simply a metal disc with a circular hole in the center which is placed directly in front of the lens. Four orifice discs are available with cen-

ter-hole diameters of 3/8, 1/4, 3/16 and 1/8 inch. These discs are installed with retaining rings in the flange at the edge of the 1/2-inch NPT female pipe thread for the purge air. An internal type retaining ring is first installed by positioning the ring in the machined-groove inside the flange opening from the housing side. The orifice disc is then fixed in place tightly between the two retaining rings. Install the retaining ring (or, “snap” ring) in the machined groove inside the flange, from the housing side.

Usually, an orifice disc with a larger-diameter hole is tried first. There will be a reduction in signal, so readjustments will be required following the steps outlined in the section **INITIAL SET UP**. If the discrimination is still not satisfactory, then try an orifice disc with a smaller-diameter hole.

Generally speaking, orificing should always be considered when the burner(s) are large (50K lbs of steam and up), particularly when the S509 and S512 viewing heads are used. The table in Figure 14 shows the signal reducing characteristics of the dif-

Aperture (Hole)	F <sub>n</sub> (f Stop)	Relative light passing power
1"	2	1
3/8"	5.3	1/8
1/4"	8	1/16
3/16"	10.7	1/32
1/8"	16	1/64

**FIGURE 14 - ORIFICING: SIGNAL-REDUCING CHARACTERISTICS OF DISCS**

ferent orifice discs.

**SIGNAL SOURCES**

Testing the viewing head with signal sources other than flame can result in erroneous readings. Flame is composed of a basic “brightness” radiation with superimposed flicker of usually not more than five per cent. These flicker components vary, in a random fashion, from zero frequency (DC) to relatively high frequencies (1K Hz and up). As explained pre-

viously, the viewing head has been designed to respond to actual flame signals so that discrimination can be achieved between the flame being monitored and unwanted background.

Signal sources other than flame, such as incandescent or fluorescent light, can cause false readings that should be understood.

For example: fluorescent light is nonsinusoidal in character, meaning that there is a sharp peak when the fluorescent tube fires on the positive AC power cycle with a less amplitude excursion on the negative cycle, resulting in a radical voltage swing in the amplifiers employed in the viewing head. This sharp peak causes the first-stage amplifiers (AGC circuit for photovoltaic photodetectors) to react violently, resulting in downstream signal perturbations that are not normal. This can be even worse if a strobe light is used as a signal source.

An incandescent light source is sinusoidal in character, resulting in a less “disturbing” signal for the viewing head, but still does not resemble a true flame source because of the large AC/DC component present. The element in an incandescent light produces radiation in step with the AC power cycle, effectively turning on and off 120 times per second. There is a certain amount of thermal inertia, so that the element doesn’t turn off completely, but the large ratio of ON to OFF (AC/DC) still prevails. A more realistic, simulated signal source can be created by employing an AC to DC power supply with superimposed ripple feeding an incandescent lamp. If the 120 Hz AC ripple is about 10 per cent, then this signal source can be used to more closely resemble a flame source – keeping in mind that the simulated flicker is a single frequency of 120 Hz.

Consideration should be given to the effects of presenting a single-frequency, simulated flame source to the downstream, four-position filter.

For example: if an incandescent light source is used, powered by the 60 Hz line, switching from LL to L position will not

affect the 120 Hz signal at all, because of the cutoff frequency of 36 Hz and 71 Hz respectively, providing the downstream stages of amplification are not saturated (sinusoidal 120 Hz signal amplified to resemble a squarewave caused by waveform clipping of the operational amplifiers). If this signal is saturated, then switching from LL to L may indeed cause a higher reading in the signal processor, caused by the squarewave type waveform presented to the filter. For this reason, it is important not to judge the filter performance when using this type of signal source.

In general, it is appropriate to use signal sources powered by the 60 Hz line for viewing head cursory checking, but obviously not for definitive performance. No detrimental effects will result from using signals that saturate the viewing head amplifiers.

## ANGLE OF VIEW OF VIEWING HEAD

The angle of view of the IRIS S509 viewing head has been specified at 2.8 degrees. A description of what this means is given in this manual (see 2<sup>nd</sup> paragraph, section **DETERMINING SIGHT PIPE SIZE**).

The angle of view is a function of the focal length of the lens and the size of the photodetector element. The equation for angle of view of a camera lens is:

$$2F \tan \alpha/2 = d$$

where F = effective focal length of lens

$\alpha$  = angle of view

d = diagonal of negative

so that the angle  $\alpha$  is:

$$\alpha = 2 \tan^{-1} d/2F$$

The diagonal of the negative is used for photographic reasons related to the size of the negative, but a better measure for the purposes of this explanation would be the diameter of a circle. The photodetector element used for the S509 is 2.0 x 2.5 mm, which is nearly square, and the longer side is used for the angle-of-view calculation (2.8 degrees).

The PbS element used in the S512 is 2.0 x 2.0 mm square. If you take the area of this element (4 mm<sup>2</sup>) and find a circle of the same area, the diameter will be 2.2568 mm. This was derived as follows:

$$\text{Area circle} = \pi R^2$$

$$\pi R^2 = 4 \text{ mm}^2$$

So  $R = (4/\pi)^{1/2} = 1.1284$

And  $\text{dia} = 1.1284 \times 2 = 2.2568 \text{ mm}$

or  $\text{dia} = 0.0889 \text{ inches}$

Using the same 2 inch focal length lens and making this diameter equal to d we get:

$$\alpha = 2 \tan^{-1} d/2F$$

$$\alpha = 2 \tan^{-1} 0.0889/2 \times 2$$

$$\alpha = 2.545^\circ$$

The equation for angle of view of a camera lens is derived from:

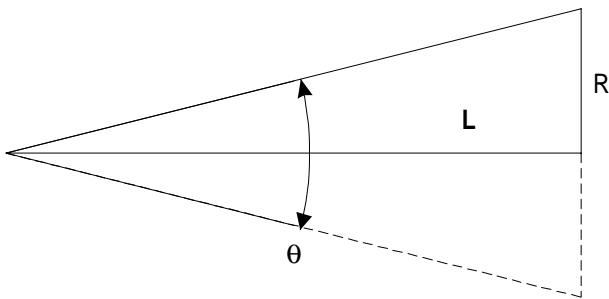

where  $\tan \alpha/2 = R/L$  and  $R = L \tan \alpha/2$

L		DIA
FT	INCHES	INCHES
2	24	1.07
3	36	1.60
6	72	3.20
12	144	6.39
16	192	8.53

**FIGURE 15 - VIEWING HEAD: ANGLE OF VIEW - DISTANCE AND DIAMETER**

The diameter  $d = 2L \tan \alpha/2$  which is the same equation as before with  $F = L$  but now  $d$ , will be the diameter instead of the diagonal.

If you use  $\alpha = 2.545^\circ$ , then the above equation resolves to:

$$\text{dia} = L (.0444)$$

The table in Figure 15 shows the various distances (L) versus the diameter of the circle of view for the S512 viewing head.

**APPLICATION OF IRIS VIEWING HEADS**

It is impossible to provide steadfast rules for each type of viewing head and what application it should be used for. The applications are becoming more difficult because of the wide range of fuels being used, in addition to recent changes in burner design to comply with clean air standards.

The S506 UV viewing head will always result in excellent discrimination between burners. The key factor in using the UV type detector is obtaining a consistent and reliable signal under all conditions. UV radiation is very susceptible to being absorbed and blocked by non-hydrocarbon elements and unburned fuel, as explained before. UV type detectors usually work very well on natural gas. However, low NOx type burners (controlled combustion) utilizing *fuel gas recirculation* (FGR) can cause problems with UV flame detection.

The S509 “two-colour” photodetector viewing head has been very successful in sulfur recovery applications (Claus reactors) in the gas processing and petrochemical industries. The basic drawback is the nonlinearity of the Si channel caused by the AGC action, as previously explained (see section **S509 VIEWING HEAD**, and section **S512 VIEWING HEAD**). Also, the Si channel will not see natural gas.

The S511 Ge viewing head will detect all types of flames (fuels) and has been very successful in detecting flame in lime kilns and sulfur recovery reactors. The only drawback is the poor discrimination between burners.

The S512 (PbS only) viewing head will detect all types of flames (fuels). The basic drawback (which can be corrected by orificing) is the photodetector saturation on bright flames.

In general, flicker-type detectors work very well when the combustion air, at the root of the burner, is turbulent. They work better on heavy oil and pulverized coal flames than on natural gas flames. Natural gas burners usually exhibit lower flicker frequencies than oil burners, particularly the low NO<sub>x</sub> type burners. UV type detectors work very well on natural gas, but they are not so good on oil flames, and work poorly on pulverized coal flames.

### **LOW NO<sub>x</sub> APPLICATIONS**

Since the advent of low NO<sub>x</sub> burners and combustion techniques to reduce emissions, the application of flame monitors has been radically changed (i.e., an infrared flicker flame monitor will not discriminate between burners in boilers utilizing low NO<sub>x</sub> gas burners). This is particularly true if FGR is being used. Only a UV flame monitor with a wide linear range (S506) can be used. In this type of application, UV radiation is spread out all over the furnace; but the more intense radiation is concentrated at the root of the flame envelope, so the flame monitor must be aimed at this zone.

On the other hand, a UV flame monitor will not work on a low NO<sub>x</sub> oil flame, because there is little UV radiation detectable from this type of staged combustion. Only an infrared flicker-type flame monitor (S509, S512) will discriminate between burners.

The tables in Figure 16 show most of the common applications and the viewing heads recommended for them. If you have enquiries regarding applications that are not listed, please contact Bob Langthorne at IRIS Systems Inc. for recommendations.

### **APPLICATION OF P520**

Great effort has gone into designing the P520 signal processor to make it fail safe. When properly installed and functioning as designed, it functions as a safety device that will provide protection from boiler or furnace explosions.

However, the output of the flame relay in most installations is not used directly to control the fuel valves. The circuitry used between the flame relay and the safety shutoff valve solenoid should be carefully examined.

For example: a condition where the flame relay of the P520 feeds only to a *programmable logic* controller (PLC), and the PLC controls the fuel valve, represents a dangerous installation with the potential for a serious explosion.

### **USING A PLC WITH IRIS FLAME MONITOR**

PLCs are *inherently* unsafe when used by themselves.<sup>1,2,3</sup> Schemes have been devised to make them safe – such as feeding outputs back to the inputs to check the outputs; using multiple outputs in series for redundancy; and using “watchdog timers” that presumably detect malfunctions. None of these methods will make a PLC critical control loop 100 per cent safe.

PLCs **cannot and should not** be used by themselves for burner control or burner management systems without external protective circuitry to make them 100 per cent safe. The critical loops that must be protected are the *main fuel trip* (MFT) functions; initial burner/igniter light off; subsequent continued burner firing with flame monitoring; and burner shutdown.

Most burner control systems are designed for overall, fail safe operation. “Fail safe” means that, in the event of a failure of any component(s) or power, the burner or boiler will be shutdown safely. This usually is accomplished by devices such as valves, solenoids and relays that use springs to return them to a safe state when energized.

Burner control systems designed for power-to-open and power-to-close type systems are different because of the storage battery backup upon loss of AC power. However, the philosophy of fail safe concepts and safety with regard to critical loops is the same.

The external, protective circuitry required for the boiler-common MFT function can be as simple as using a single relay energized by a string of contacts in series that would include the usual permissives, proper air flow, fuel pressure, fuel temperature, etc.

**IRIS MODEL P520 APPLICATION MANUAL**

**TABLE OF IRIS VIEWING HEADS AND PERFORMANCE WITH VARIOUS FUELS**

(DISC=discrimination between burners and flameing background\*, SIG=signal strength)

**GAS (HYDROGEN, PROPANE AND NATURAL GAS)**

<b>MODEL #</b>	<b>TYPE</b>	<b>COMMENTS</b>	
S506	UV	DISC excellent	SIG very good
S509	PbS Only	DISC good <sup>1</sup>	SIG good
S509	Si	NOT GOOD - WILL NOT SEE THIS FUEL	
S511	Ge	DISC fair	SIG good
S512	PbS	DISC good <sup>1</sup>	SIG good
S550	UV & PbS	DISC excellent	SIG very good
S552	PbS Only	DISC good	SIG good
S556	UV Only	DISC excellent	SIG very good

**GAS LOW NO<sub>x</sub> BURNERS**

<b>MODEL #</b>	<b>TYPE</b>	<b>COMMENTS</b>	
S506	UV	DISC good	SIG good
S509, S512	PbS Only	DISC none	SIG fair
S550	UV & PbS	DISC excellent	SIG very good
S552	PbS Only	DISC none	SIG fair
S556	UV Only	DISC excellent	SIG very good

**FIGURE 16 - VIEWING HEAD APPLICATION TABLES**

**OIL (HEAVY OIL - air & steam atom)**

MODEL #	TYPE	COMMENTS	
S506	UV	DISC excellent	SIG poor <sup>2</sup>
S509	PbS Only	DISC very good	SIG good
S509	Si	DISC poor	SIG very good
S511	Ge	DISC fair	SIG very good
S512	PbS	DISC very good	SIG good
S550	UV & PbS	DISC excellent	SIG very good
S552	PbS Only	DISC very good	SIG very good
S556	UV Only	DISC excellent	SIG poor <sup>3</sup>

**PULVERIZED COAL**

MODEL #	TYPE	COMMENTS	
S506	UV	DISC excellent	SIG very poor <sup>2</sup>
S509	PbS Only	DISC good	SIG good
S509	Si	DISC fair	SIG good
S511	Ge	DISC poor	SIG very good
S512	PbS	DISC good	SIG good
S550	UV & PbS	DISC excellent	SIG very good
S552	PbS Only	DISC very good	SIG very good
S556	UV Only	DISC excellent	SIG very poor

\* Flaming backgrounds such as wood waste, black liquor etc.

<sup>1</sup> Not so good if background fuel is wood waste grate fired.

<sup>2</sup> Usually inconsistent, not reliable.

<sup>3</sup> Can be very good depends on the amount of Atom. steam or air

**FIGURE 16 - VIEWING HEAD APPLICATION TABLES Cont'd**

More elaborate designs involving the PLC for alarming or prompts, in addition to diagnostic functions, will complicate the MFT circuitry, but the underlying philosophy must be to maintain an external, direct, fail-safe function.

Also, consideration should be given to the air-purge timing function. The dangerous condition occurs when the purge timer times out short of the required time delay. One way to overcome this type of malfunction is to use an auxiliary timer, so that a time out of both the PLC and the auxiliary timer is required before light off (AND relationship).

The wiring diagram in Figure 17 shows a basic igniter/burner circuit that can be used with a PLC to accomplish the safe operation of a burner or burners in a multiburner installation. Note that the *burner shutdown* (BURNER STOP SW) is included; this circuit is equally as critical as flame monitor protection.

### BASIC BURNER START CIRCUIT

The sequence of operations for the basic burner start circuit (refer to Figure 17) is as follows:

1. Pressing the start button (START P.B.) will start the ignition sequence, providing there is no MFT present, purge is complete and all the limits for firing are satisfactory, and no flame is being detected. This latter function is the “safe-start-check” jargon common in the flame safeguard industry. Note that the PLC is started at the same time as *time delay 1* (TD1) is pulsed ON. (The push-button switch must be actuated for at least 50 milliseconds to ensure the *Delay After De-Energized* (DADE) timer is started.)
2. The *master relay* (RM) Contact pulls in, sealing the loop around the *flame relay* (RF) contact, normally closed. The RM contact provides the current path to the ignition transformer and igniter valve. Note that the igniter valve contact from the PLC must be commanded closed at this time. A master relay is used so that there is adequate current-carrying capacity, which may not be the case for using

the flame relay contacts by themselves. (The P520 flame relay contacts are rated to 2 Amps at 220 VAC.) Alternatively, additional, normally-open RM contacts can be used, either in series or parallel, to accommodate the load requirement (sometimes, two contacts in series are used to minimize contact wear caused by inductive arcing when contacts are open).

3. The DADE timer will time-out, opening the contact around the RF contact. If there is no flame detected, the RM will drop out, shutting down the sequence.
4. Once flame is detected, the PLC logic sequence can continue by opening the burner valve, and then after a time delay, closing the igniter valve (this is called “interrupted igniter operation). The only necessary requirement is that the burner valve(s) be powered by RM contact(s), as shown. A subsequent flame failure will cause the RM to drop out, de-energizing the main fuel valve(s), regardless of the state of the PLC.

This wiring diagram is not intended to illustrate all the logic that would normally be used in a multiburner system, but to show only the bare essentials required to make the PLC safe. Such functions as low-fire permissive on first burner started, flameout alarm and reset, main burner time trial for ignition, and igniter shutdown, would be part of the PLC logic.

Occasionally, it is necessary to use two viewing heads –one for the igniter and one for the burner– with one signal processor. In this case, you can switch between them (using one head at a time): the igniter viewing head when proving igniter flame, and the burner viewing head for proving main flame (refer to section **MULTIPLE VIEWING HEADS**).

A safe-start-check would have to be made on both viewing heads; you do not want to start up a burner if it is already reading other flames. You can do this by looking at both flame monitors in parallel (switch both inputs together feeding terminal A28 on the Euro

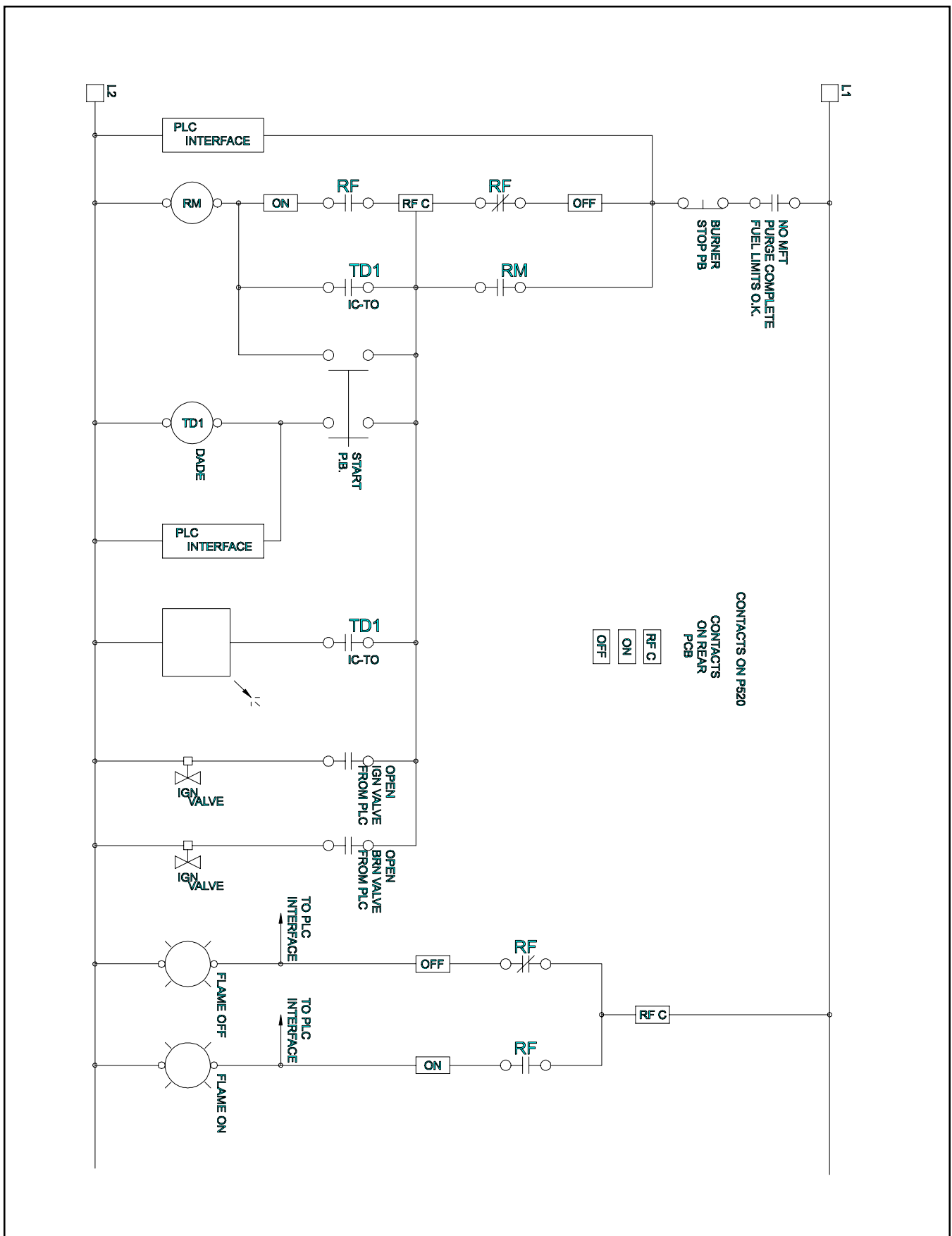

FIGURE 17 - BASIC BURNER START CIRCUIT

Card connector or, if a rear backplane PCB is used, by connecting together the SIG and SIG GND terminals on each block) before starting the ignition sequence. This will result in the normally-closed RF contact on the P520 having to be closed in order to start the burner. This parallel viewing head operation should only be used for the start-up sequence, because adding the flame signals together increases the unwanted background that results in poor discrimination.

The BASIC BURNER START CIRCUIT shown (Figure 17) is a basic circuit requiring only two pieces of external hardware for each burner:

1. Master Relay with at least two normally-open contacts rated for load.
2. DADE Timer, with two *instant close/timeout open* contacts.

\* \* \*

1. Bryant, *Design of Fail-Safe Control Systems*, Power, January, 1976.
2. Bryant, *Is Your Plant's Control System Safe?*, Power, August, 1979.
3. Fischer, *Are PLCs Suitable for Emergency Shut-Down Systems?*, Presented at 43<sup>rd</sup> symposium for the process industries, Texas A & M University, 1988.

## MODULE COMMUNICATIONS

The P520 communicates with any host computer that has an RS-232 serial I/O port and supports ASCII character code transmission at 4800 baud (or, in current revisions of the processor chip, at 4800 or 9600 baud). The baud rate is displayed with the module address in the current versions (see **SETTING ADDRESSES**, section). The data transmitted to and from the P520 is over two twisted pairs that are differentially driven and received according to the RS-422 standard. The differential mode allows long wire runs in harsh, electrical environments.

## MODBUS COMMUNICATION

Modbus Communication for IRIS P520 Flame Monitoring System Signal Processor.

## Introduction

Modbus Communication protocol allows the P522 to communicate with any process controllers or human-interface host computers that support this protocol. The P520 processor status and settings are organized as 23 4X holding registers and five 0X discrete registers. For more information on Modbus protocol, please refer to Modicon's Modbus Protocol Reference Guide (PI-MBUS-300 Rev E).

## Communication Setting

The P520 can communicate only in Modbus RTU mode, with the following configuration:

- 9600 baud
- 8 data bits
- no parity
- 1 stop bit

The factory default of a P520 station number is 0. It is important to change the station number so that there is no duplicate stations. To change or check the station number:

- Press and hold Reset button for 4 seconds
- The 4 LED digits will show the baud rate and the station number. The 2 leftmost digits are the baud rate (96 or 48); the 2 rightmost digits are station number. (0 to 63)
- Press up/down button to change the station number.
- Press Store button to save station number.

## Protocol Detect

The P520 with firmware version 5.0 still supports the existing IRIS protocol. After power-up, processor will listen for both protocols. Once the protocol has been detected, communication must remain in this protocol until the unit is powered off.

## MODBUS RTU Function Supported

Four Modbus functions are supported:

- 01 Output Coil Read
- 03 Holding Register Read
- 06 Preset Single Holding Register
- 16 Preset Multiple Holding Register

## Registers Map

### 4X OR NUMERICAL REGISTERS:

400001	Flame Count Of Active Channel (read only)
400002	Processor Status (read only)
400002/0	View head/Channel Selected (0=Channel A)
400002/1	Flame On Relay Status
400002/2	Processor Lockout Status (0=lockout)
400002/3	Panel Access Disabled (0=disabled)
400002/4	4-20 output Status (0=0-40)
400003	Flame On Channel A
400004	Flame On Channel B
400005	Flame Off Channel A
400006	Flame Off Channel B
400007	Gain Channel A
400008	Gain Channel B
400009	IR Analog Gain Channel A
400010	IR Digital Gain Channel A
400011	IR Filter Channel A
400012	UV Gain Channel A
400013	IR Analog Gain Channel B
400014	IR Digital Gain Channel B
400015	IR Filter Channel B
400016	UV Gain Channel B
400017	View Head Type Channel A (read only)
400018	View Head Type Channel B (read only)
400019	Temperature Channel A (read only)
400020	Temperature Channel B (read only)
400021	Time Delay on (Upper nibble = B lower = A)
400022	FFRT (Upper nibble = B lower = A)
400023	Firmware Version # (read only)

### 0X OR DISCRETE REGISTERS: (All read only)

000001	View head/Channel Selected (0=Channel A)
000002	Flame On Relay Status
000003	Processor Lockout Status (0=lockout)
000004	Panel Access Disabled (0=disabled)
000005	4-20 output Status (0=0-40)

## Communicating with Modicon PLC

Each Modicon PLC comes with a Modbus port. The control program can read/write the settings from/to the P520/P522 scanner via this port. A XMIT loadable module is needed to send Modicon functions. XMIT loadable module is available from Modicon Inc.

*Note:* Not all models of Modicon PLC's will accept the XMIT loadable module. Please consult you local Modicon dealer for more information.

## COMMUNICATION WITH HUMAN-INTERFACE HOST COMPUTER

A number of Modbus drivers for Microsoft Window 95 and NT are available from the third party developer, such as Rockwell Software's WinTelligent Linx Modicon. A Modicon driver driver allows application programs such as Microsoft Excel, Wonderware and RSView to communicate with the P520 scanners directly

## RS-232 to RS-422 CONVERSION

It is necessary to use a RS-232 to RS-422 converter at the host computer. The IRIS COMM converter module can be used, and is recommended because of its photocoupler isolation. The converter must have galvanic ground isolation.

## SETTING ADDRESSES

Each P520 must have its own unique address. The address is easy to change. Press the RESET push-button for >2 seconds, causing the P520 to immediately display its address on the four-digit display (0000 to 0063), and change using the UP or DOWN arrow buttons. When the desired address is displayed, push the STORE button, and the P520 will immediately respond to this new address.

In current software revisions of the processor (versions 3.0 and higher), the baud rate can also be changed when the module address is changed. The baud rate is displayed in the highest two digits of the numeric display (i.e., 4802 is 4800 baud and address 2). To change to 9600 baud, increase the display past 4863. The next display will be 9600, which is 9600 baud, address 0. Then increase the display further to the desired address. To return to 4800 baud, reduce the display below 9600, and set the desired address.

**TECHNICAL HELP**

For technical assistance in installing this product,  
please contact:

**Sales and Corporate Office:**

IRIS Systems Inc.  
#205, 19138 26th Ave  
Surrey, B.C. V3S 3V7  
Canada  
Phone: (604) 584-4747  
Fax: (604) 581-9790

**Manufacturing:**

IRIS Systems Inc. (J.B. Systems Inc.)  
4944 - 113th Avenue North  
Clearwater, Fl 33760  
Phone: (727) 545-3900  
Fax: (727) 547-9589

# SPECIFICATIONS

## ELECTRICAL

- Input Power (with one V.H.) - 26Vdc +5%, -20%, 300mA  
(100mA for each additional V.H.)

## ENVIRONMENTAL

- Ambient Temperature - Viewing Head NEMA TYPE 4
- P520 Signal Processor 0°C to +50°C
- S506, S509, S511, S512, S513\* 0°C to +60°C
- S580\* -54°C to +177°C
- Case Temperature - S506, S509, S511, S512, S513\* 0°C to +60°C
- S580\* -54°C to +177°C

## OPTICAL

- |                         |   |      |             |                  |             |
|-------------------------|---|------|-------------|------------------|-------------|
| Angle of View (UV Tube) | - | S506 | 4 degrees   | S509             | 3.9 degrees |
|                         |   | S511 | 1.6 degrees | S512             | 3.2 degrees |
|                         |   | S580 | 3.6 degrees | S550, S552, S556 |             |
|                         |   |      | IR          | 1.0 degrees      |             |
|                         |   |      | UV          | 3.0 degrees      |             |

## Cable (Between Viewing Head and Signal Processor)

- 4 conductor, #16 AWG or #18 AWG,  
one wire shielded with braided shield for flame signal.

## OUTPUTS

- Flame Relay - 2 Form C Contacts
- Self-Checking Relay - 1 Form C Contact
- Contact Ratings
  - Max switching power 60W 125VA
  - Max switching voltage 220Vdc, 250Vac
  - Max switching current 2A dc, ac
- Analog Flame Signal - 0 to 20mA current output for remote meters and  
4 to 20mA output for DCS etc. (360 ohm max. resistance.)
- Power to Viewing Head - +26Vdc, fused 0.25A
- +14.3Vdc Pulsing 0.2 Sec ON 0.8 Sec OFF

## INPUTS

- Channel Select (Isolated Input\*\*) - VIN 7.5-30Vdc range (Input R=3900 ohms)  
26Vdc, 6.4mA  
10Vdc, 2.3mA
- Flame Signal from V.H. (Isolated Input\*\*) - VIN 7.5-30Vdc range (Input R=3900 ohms)  
13.6Vdc, 3.2mA

## SERIAL COMMUNICATION

- RS-422 (Differential) - 4800 or 9600 Baud (user selected)  
Cable requirement (2 twisted pairs)

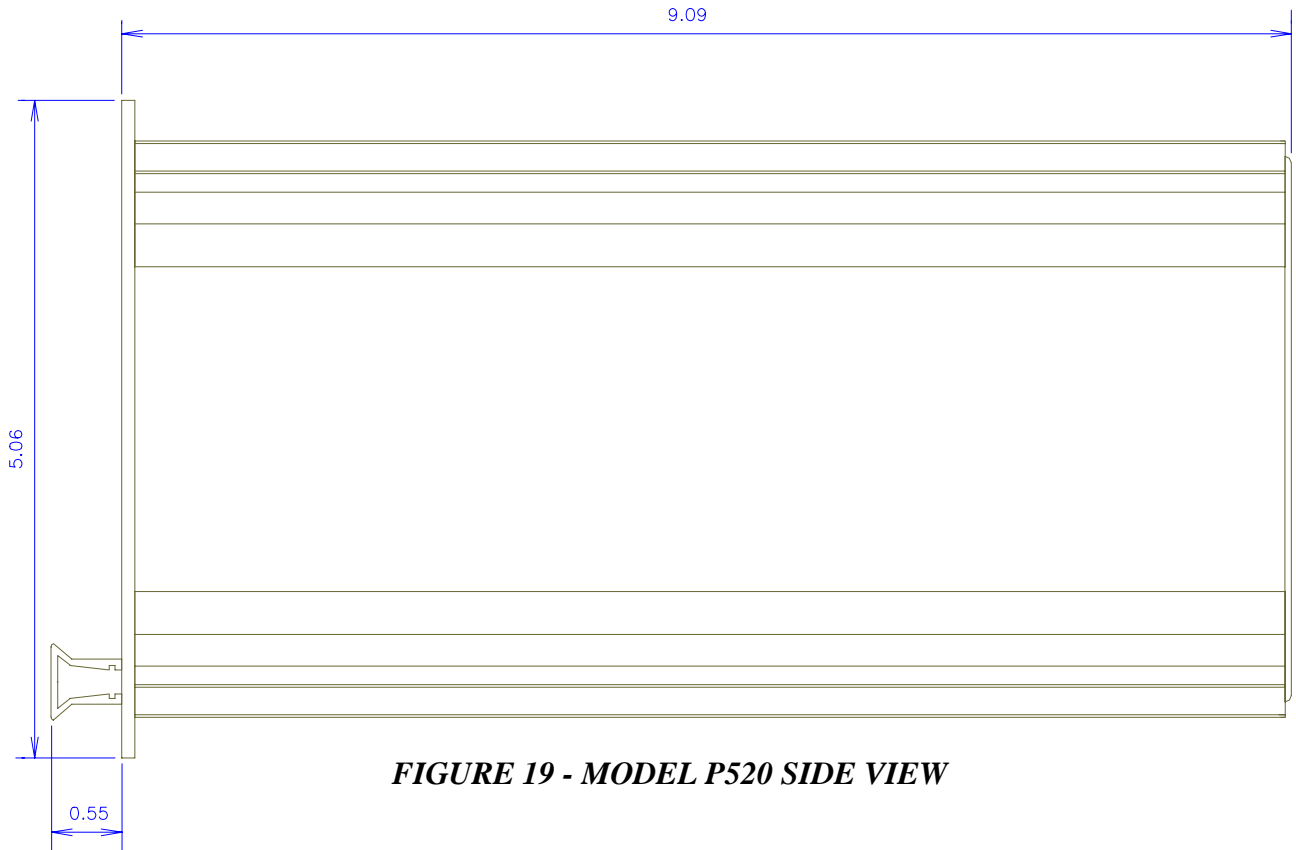

**FIGURE 19 - MODEL P520 SIDE VIEW**

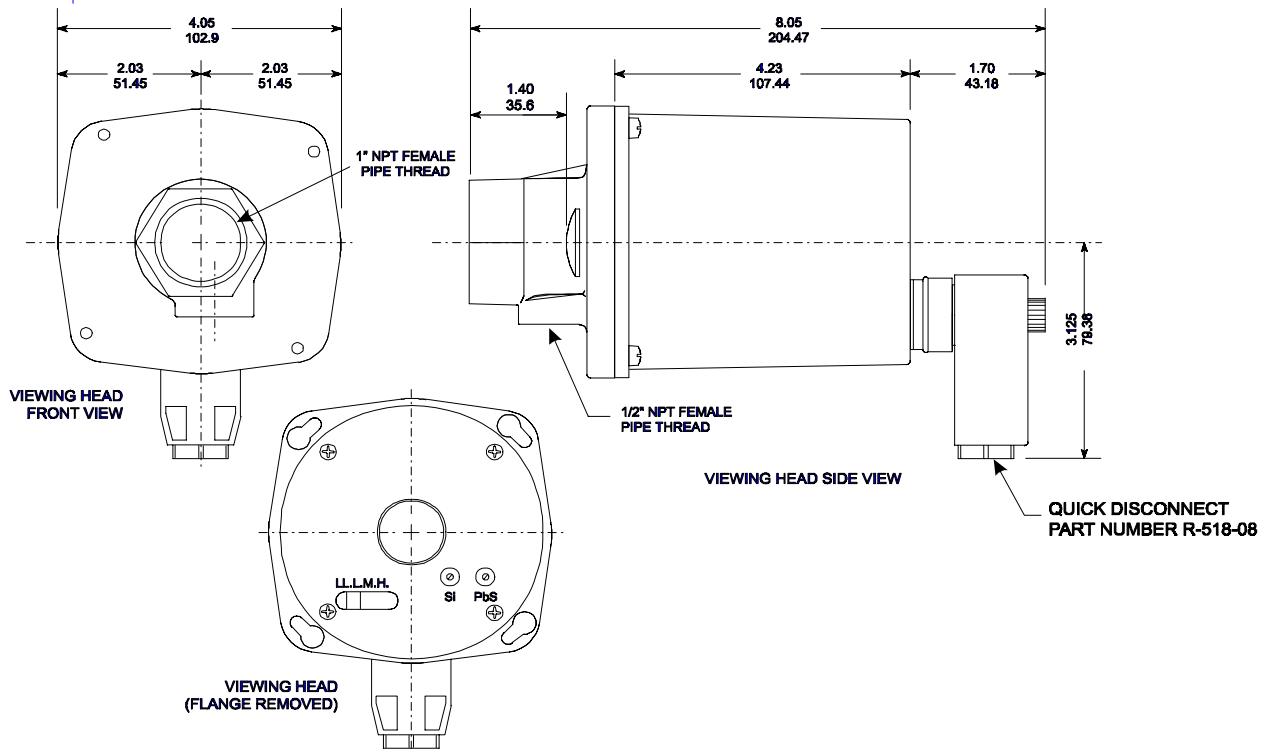

**FIGURE 20 - S5XX VIEWING HEAD DIMENSIONS**

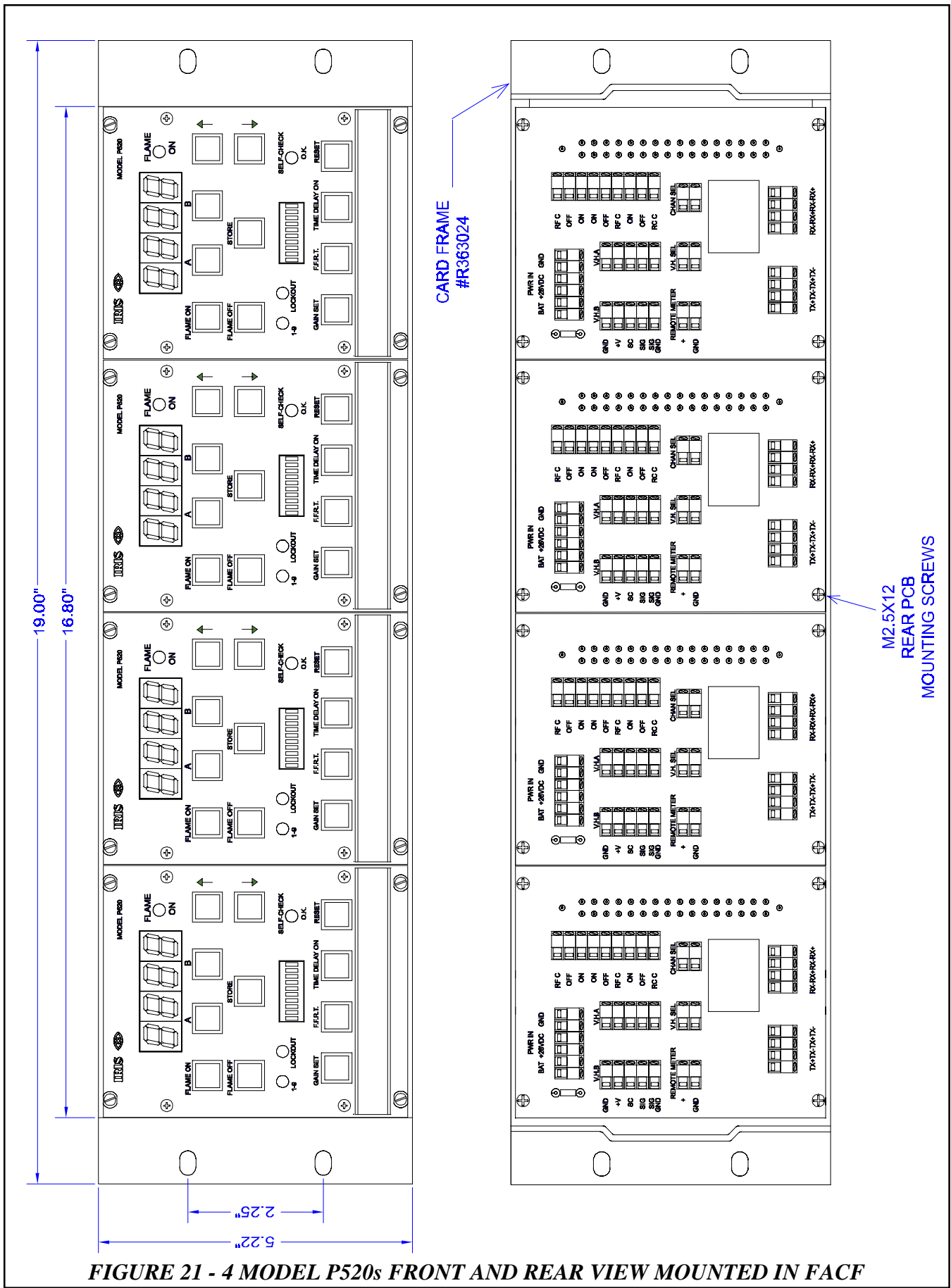

FIGURE 21 - 4 MODEL P520s FRONT AND REAR VIEW MOUNTED IN FACF

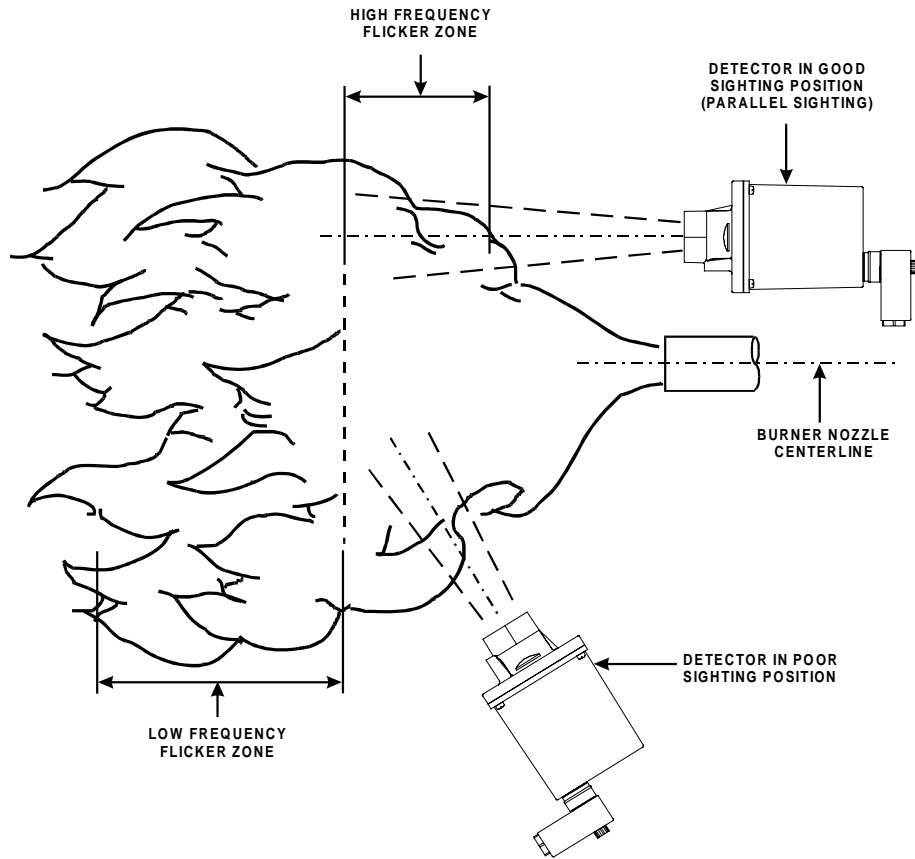

FIGURE 22 - IR VIEWING HEAD LOCATION

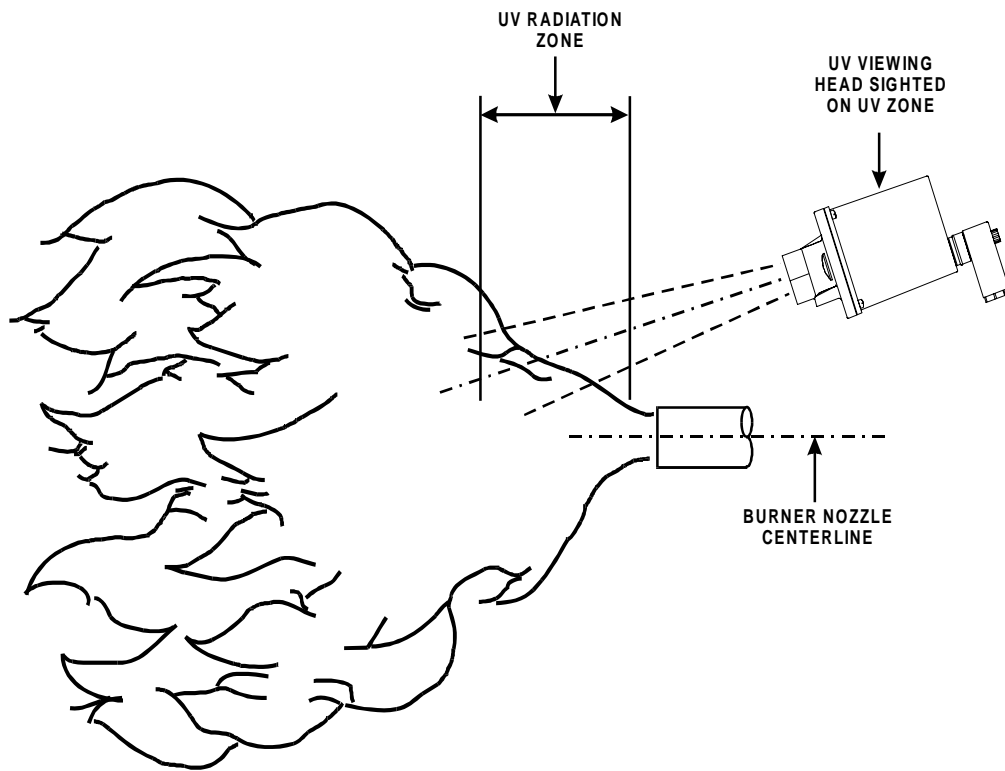
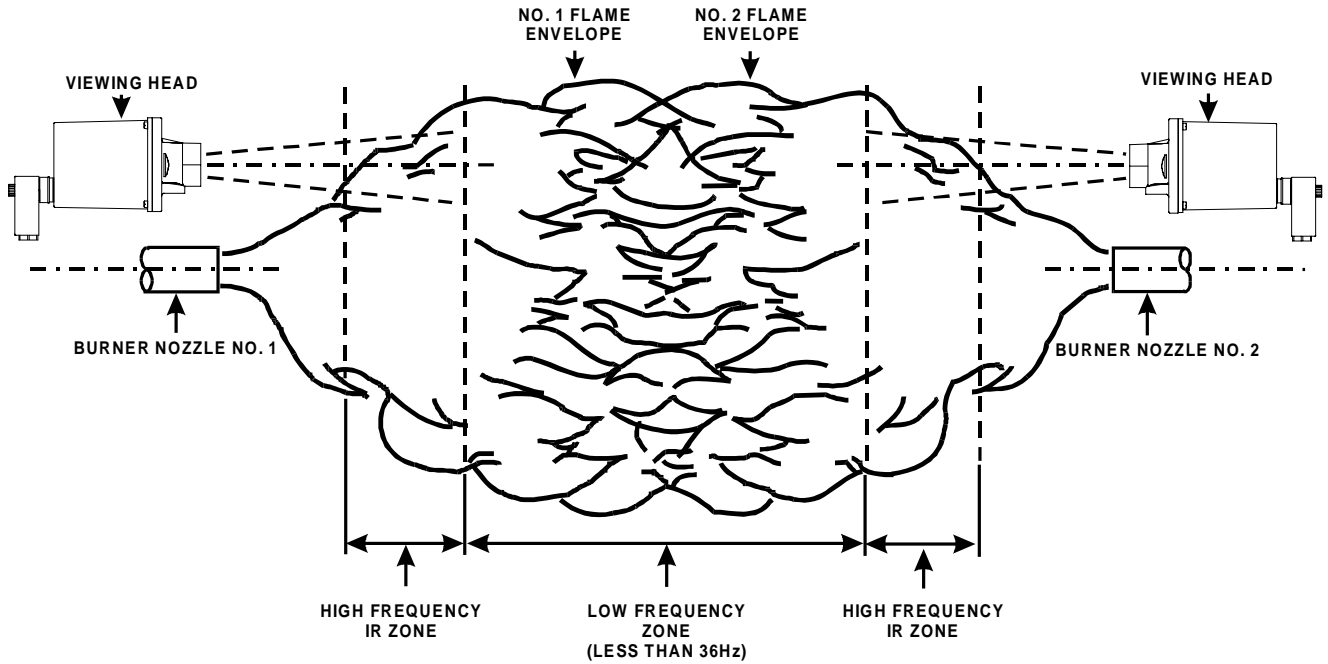
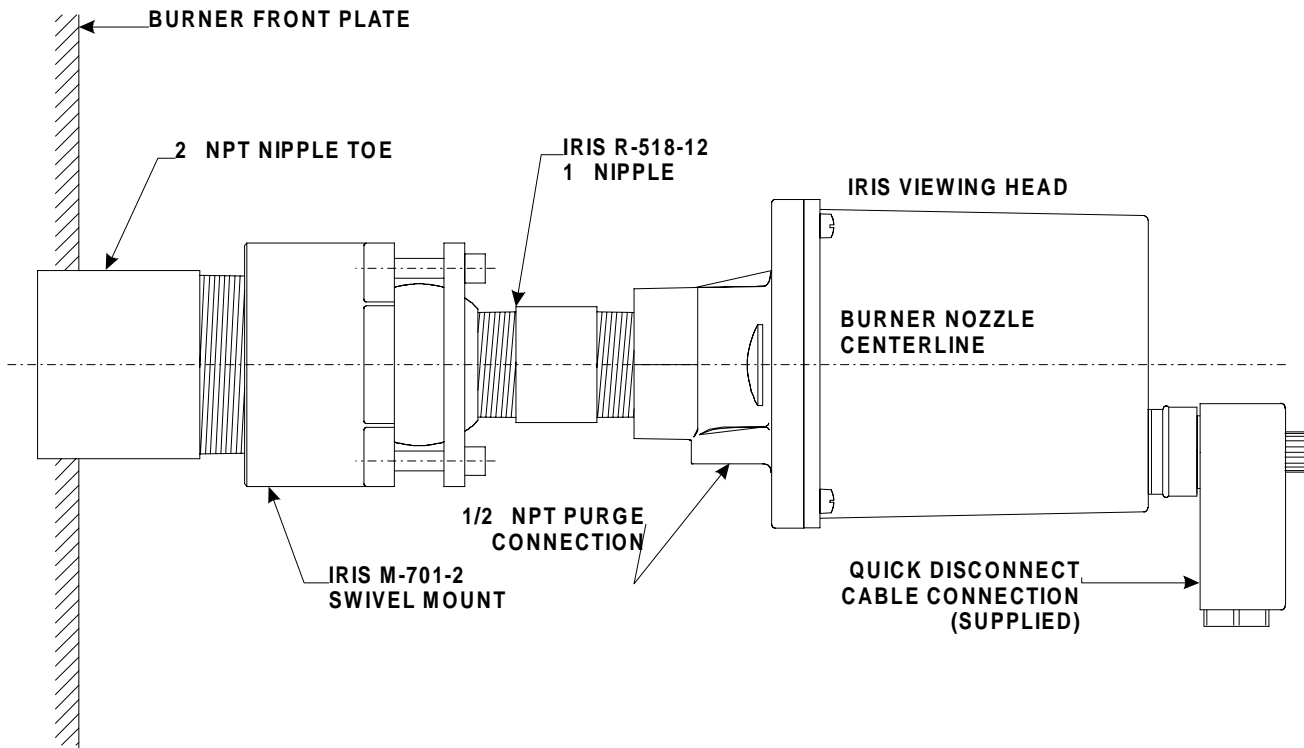

FIGURE 23 - UV VIEWING HEAD LOCATION



**FIGURE 24 - OPPOSED FIRED VIEWING HEAD SIGHTING**



**FIGURE 25 - VIEWING HEAD MOUNTING**

# Index

1-9 -----	10, 23	lockout condition -----	10, 15, 16, 19
4-20mA -----	6, 17	low NOx -----	21, 30, 31, 32
<b>A</b>			
AGC -----	22, 26, 27, 28, 29, 30	<b>M</b>	
angle of view -----	20, 21, 29	memory -----	15, 16
aperture -----	27	modbus communication -----	36
<b>B</b>			
background flame -----	21, 26	<b>N</b>	
battery -----	5, 10, 15, 24, 31	natural gas -----	18, 22, 25, 26, 28, 30
baud rate -----	36, 37	NEMA -----	11
brightness -----	19, 26, 27, 28	noise -----	17, 23
<b>C</b>			
cable -----	5, 8, 23, 24	<b>O</b>	
card frame -----	4, 5, 11, 14, 24	oil -----	19, 21, 25, 27, 28, 31, 33
channel select -----	15, 37	<b>P</b>	
com port -----	6	PbS channel -----	22, 26, 27
current --	5, 6, 9, 10, 15, 16, 17, 24, 26, 34, 36, 37	PLC -----	31, 34, 36, 37
current output -----	17, 39	power failure -----	15
<b>E</b>			
EEPROM -----	15, 16	pressure -----	18, 20, 34
enclosure -----	11, 24	propane -----	25, 26, 28
<b>F</b>			
F.F.R.T. -----	2, 17, 21	pulses -----	10, 20, 24, 25
fail-safe -----	34, 36	pulverized coal -----	18, 25, 28, 31, 33
FGR -----	30, 31	<b>R</b>	
fiber optic -----	18	relay contacts -----	14, 15, 34
filter switch -----	19, 22, 25, 26	remote meter -----	6, 17
flame relay 3, 5, 6, 11, 14, 15, 17, 19, 25, 31, 34, 39		remote meter -----	9, 17, 39
flicker -----	18, 19, 21, 22, 26, 27, 28, 29, 31	reset -----	11, 15, 16, 18, 23, 36, 37
frequencies -----	19, 27, 28, 31	registers map -----	37
fuse -----	5, 9, 23, 39	RS-232 -----	6, 36, 37
<b>G</b>			
germanium (Ge) -----	26, 30	<b>S</b>	
grounding -----	23, 24	safe-start -----	15, 34
<b>H</b>			
hydrogen -----	32	saturation -----	26, 27, 28, 31
<b>I</b>			
incandescent -----	25, 27, 28, 29	self-check -----	5, 10, 14, 15, 16, 25
information -----	36, 37	self-checking relay -----	5, 10, 15, 39
infrared -----	21, 31	serial communication -----	6, 9, 11, 16, 39
Interference -----	23, 24	silicon (Si) channel -----	22, 25, 26, 27, 28, 30
IRIS cable -----	8, 24	<b>T</b>	
<b>L</b>			
lead sulfide -----	25, 26	temperature -----	18, 27, 34, 37, 39
lens -----	18, 20, 25, 27, 28, 29, 30	time delay -----	17, 21, 34
		time delay on -----	21, 37
		<b>U</b>	
		UV -----	10, 18, 19
		<b>V</b>	
		visible zone -----	25
		<b>W</b>	
		wiring of viewing head -----	8, 24

